

MAXIMUM PRODUCT LOAD RATING: 100 kg 

IMPORTANT:

- **LOAD = WEIGHT OF PLATFORM or BARS + MOUNTING SYSTEM + ACCESSORIES + CARGO**
- **PLEASE REFER TO VEHICLE MANUFACTURER SPECIFICATIONS FOR MAX ROOF LOAD CAPACITY OF VEHICLE. THE LOWEST LOAD RATING APPLIES.**
- **OFFROAD RATING: SCAN QR CODE FOR LOCKNLOAD LOAD RATING GUIDE. REDUCTIONS MAY APPLY.**



FIRST TIME INSTALLATION

- Please read instructions carefully before installation.
- Check the contents of kit. Each LockNLoad RuggedLine has the last four digits of the kit's part number lasered in. Contact your YAKIMA dealer if any parts appear missing, incorrect or damaged.
- Clean your roof thoroughly prior to fitting the LockNLoad RuggedLine.
- Place these instructions in the vehicle's glove box after installation is complete.



TOOLS REQUIRED:

- 10 mm Socket Wrench
- 13 mm Spanner
- Trim Removal Tool
- 10 mm Breaker Bar (optional)
- Rattle Gun (optional)

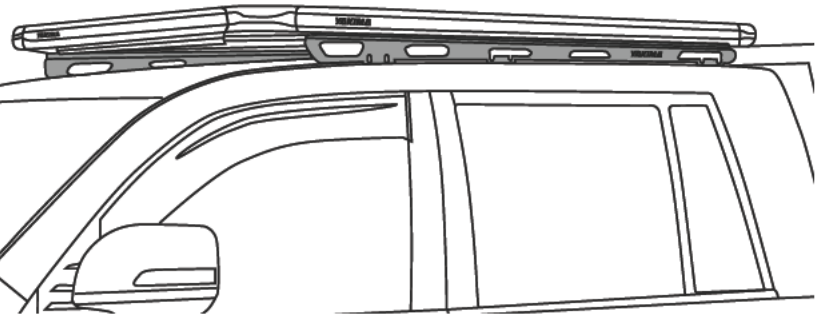

KIT CONTENTS

ITEM	COMPONENT	QTY	ITEM	COMPONENT	QTY
1.	LC200 DC RuggedLine LH 1003	x1	7.	M8 x 30 mm Socket Head Cap Screw	x12
2.	LC200 DC RuggedLine RH 1003	x1	8.	M8 Nyloc Nut	x4
3.	Pivot Bracket	x4	9.	Foam Adhesive	x12
4.	M8 x 20 mm Socket Head Cap Screw	x4	10.	Silicone Sealant	x2
5.	M8 Washer	x20	11.	4 mm T-Handle Ball End Allen Key	x1
6.	M8 Spring Washer	x12	12.	6 mm T-Handle Ball End Allen Key	x1



PLATFORM & COMPONENTS SOLD SEPARATELY
RECOMMENDED PLATFORM SIZE IS 'A' (9820337)

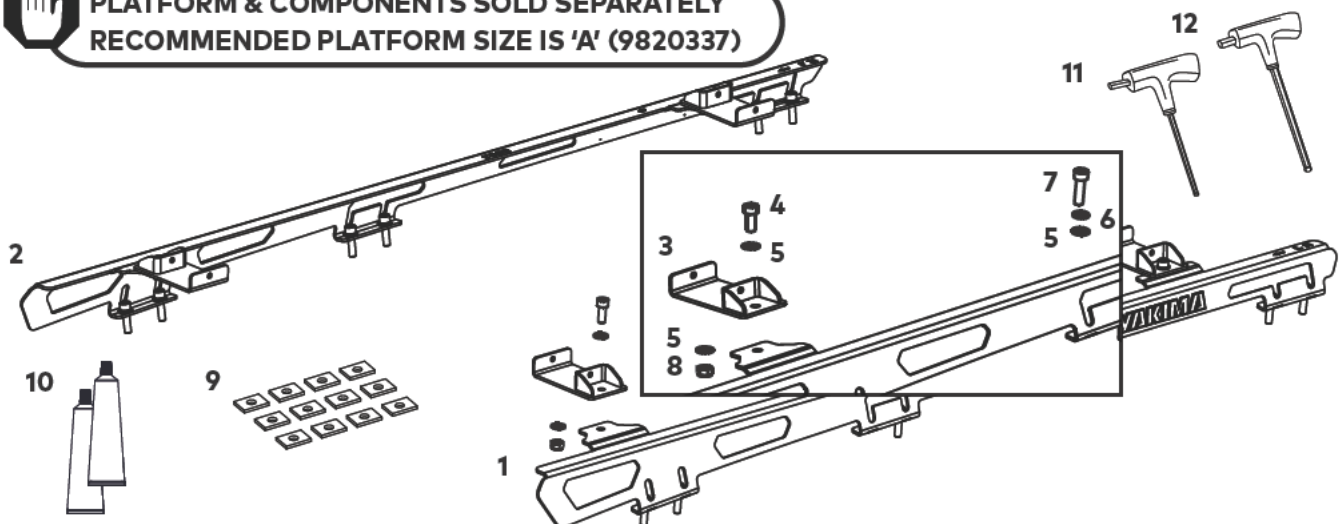

REMOVING FIXED POINT COVERS (BARE ROOF)

1 REMOVE FIXED POINT HARDWARE.

If your vehicle is not fitted with factory roof rails, remove all fixed-point covers.

Remove bolts, washers and brackets from the vehicle's fixed points.

Store removed hardware away in a safe place.

Now proceed to page 4
MOUNTING RUGGEDLINE

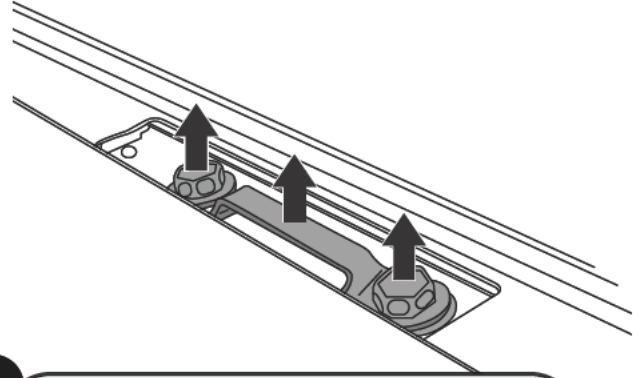

! When loosening fasteners, keep switching between them to drop tension progressively. If not, the nutplate inside the roof cavity may come loose.

REMOVING FACTORY RAISED ROOF RAILS

1a UNCLIP PLASTIC RAIL COVERS.

Using an appropriate trim removal tool, release the plastic rail end covers by carefully levering the trim removal tool downwards and squeezing the covers until the outer clips release.

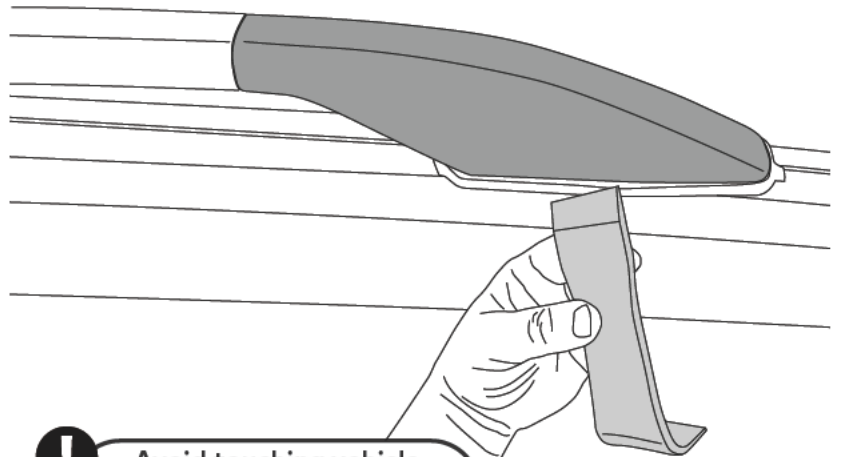

! Avoid touching vehicle body when levering trim removal tool

1b UNCLIP PLASTIC RAIL COVERS.

Once the outer clips are freed, press the cover towards the car's centre to release the clips on the inside face.

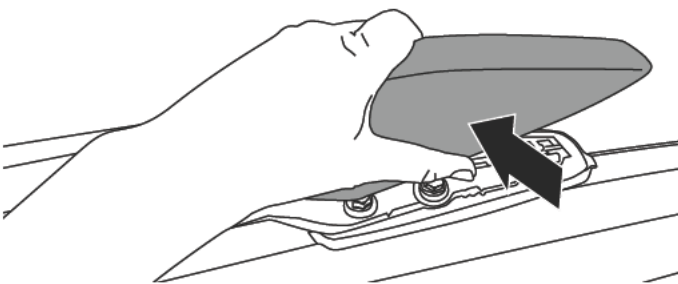

2 REMOVE PLASTIC RAIL COVERS.

Lift the detached cover and slide away from the rail.

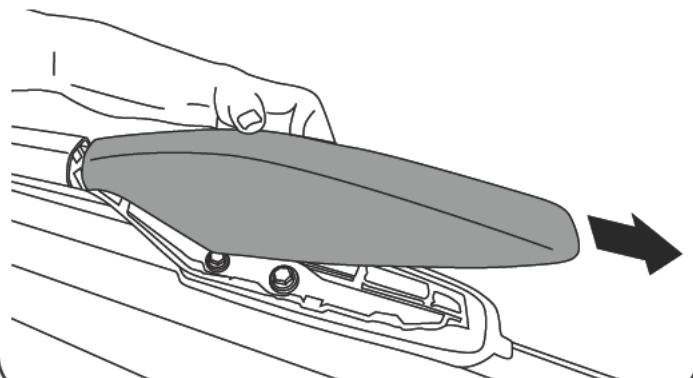

3 REMOVE COVER HARDWARE.

Remove exposed hardware using a 10 mm socket wrench or breaker bar. Complete steps 1a-3 for front and rear covers and repeat on opposite side of vehicle.

Store removed hardware away in a safe place.

NOTE - A rattle gun may be required if the factory Loctite is too difficult to break loose.

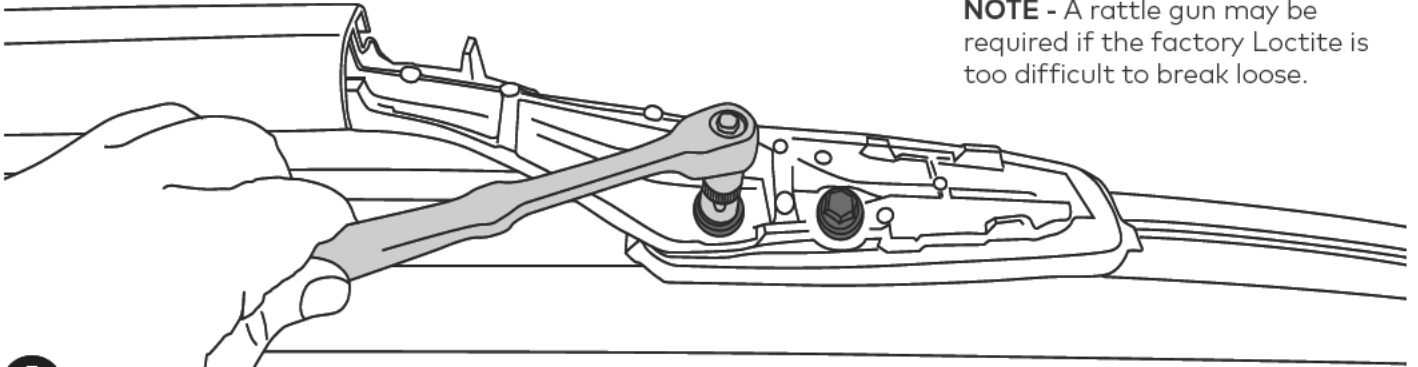

! When loosening fasteners, switch between them to drop tension progressively. If not, the nutplate inside the roof cavity may come loose.

4 REMOVE RAILS.

Lift roof rails upwards and carefully remove from the roof.

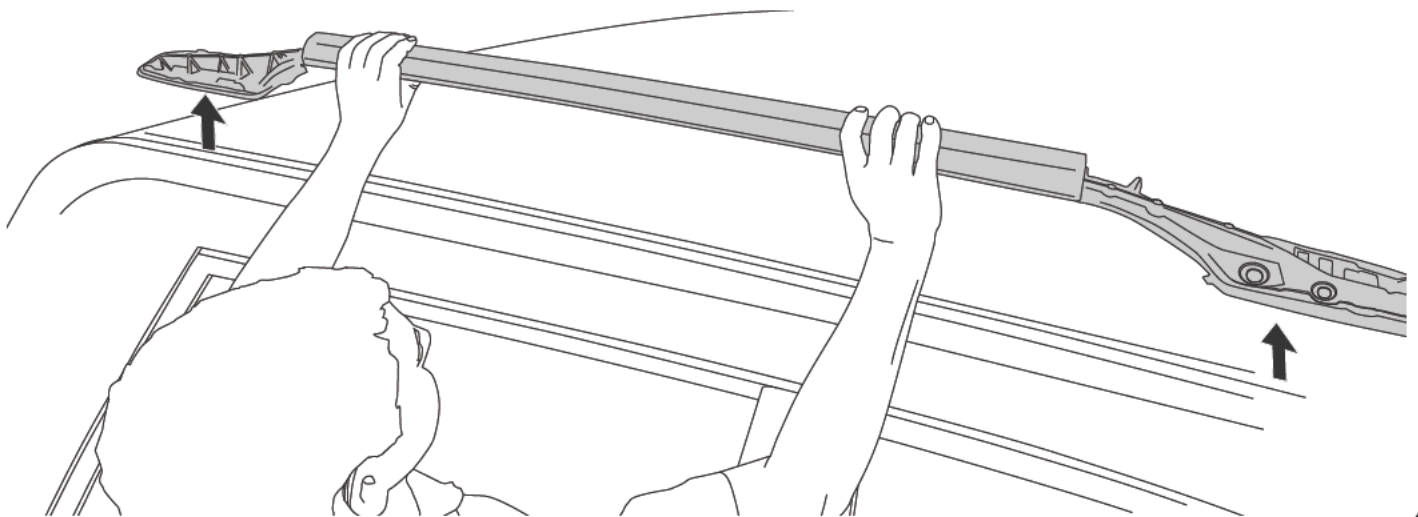

5 CLEAN ROOF.

Wipe clean any dirt that may be present in and around the mounting holes.

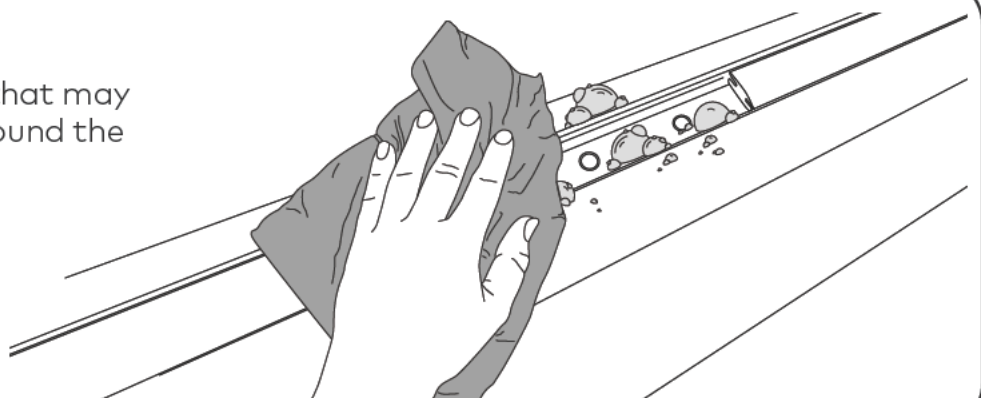

MOUNTING RUGGEDLINE

1 AFFIX FOAM ADHESIVE.

Apply foam adhesive over all 12 plastic tubes in the vehicle's mounting holes, with adhesive side to vehicle.

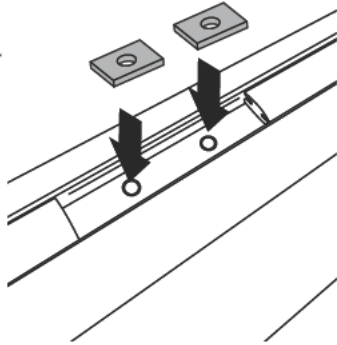

2 APPLY SILICONE SEALANT.

Liberally apply the supplied silicone sealant to the inside surface and on top of each hole **on one side of vehicle.**

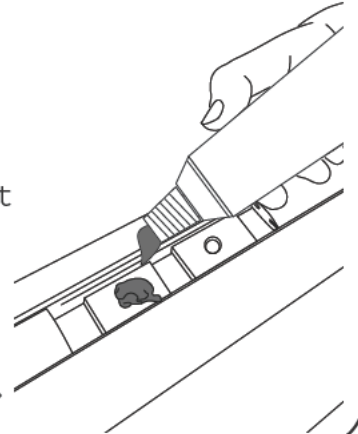

3 POSITION RUGGEDLINE ON VEHICLE ROOF.

Referring to the left-right orientation on top of each RuggedLine, carefully place one side of the RuggedLine onto vehicle roof as shown. Line up the mounting holes on the bottom tabs to those exposed on the roof. The tabs are to face in towards the vehicle.

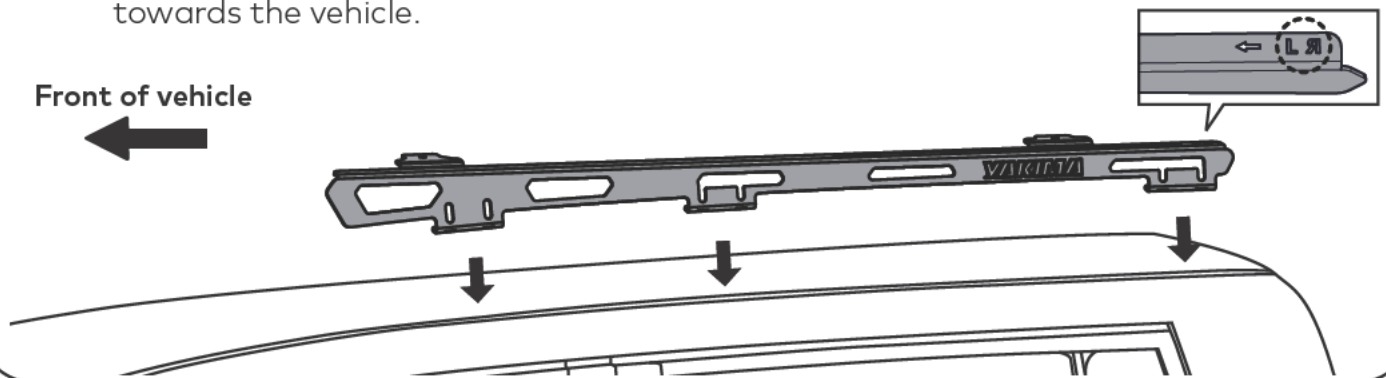

4 ASSEMBLE RUGGEDLINE HARDWARE.

Assemble the M8 x 30 mm socket head cap screw, M8 spring washer and washer as shown and place into mounting holes on bottom tabs of RuggedLine. Ensure hardware and holes align with the holes on roof.

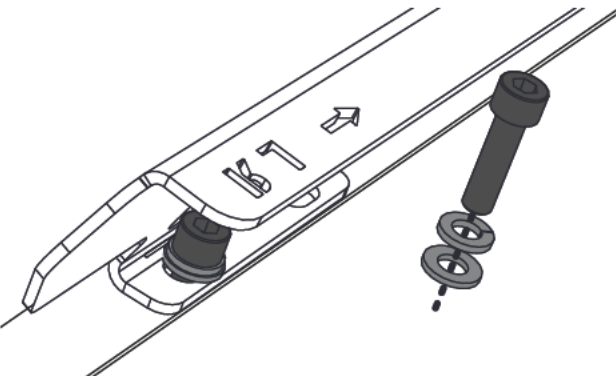

5 TIGHTEN RUGGEDLINE HARDWARE.

Using the 6 mm T-handle ball end allen key, and avoiding damage to the powder coat, start to carefully secure the RuggedLine by tightening the M8 socket head cap screws to 7 Nm into the mounting holes in roof.

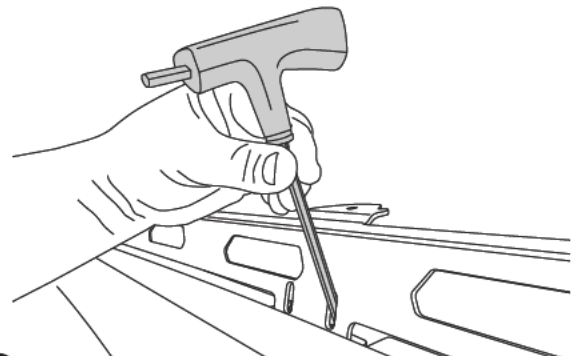

! Only fully tighten bolts once all bolts have been engaged and RuggedLine is in the correct position.

6**REPEAT STEPS TO OPPOSITE SIDE.**

Repeat steps 2-5 on page 4 for securing opposite side of RuggedLine.

Ensure both RuggedLine are securely positioned on vehicle roof. Check each screw is secure before proceeding to install LockNLoad platform to RuggedLine.

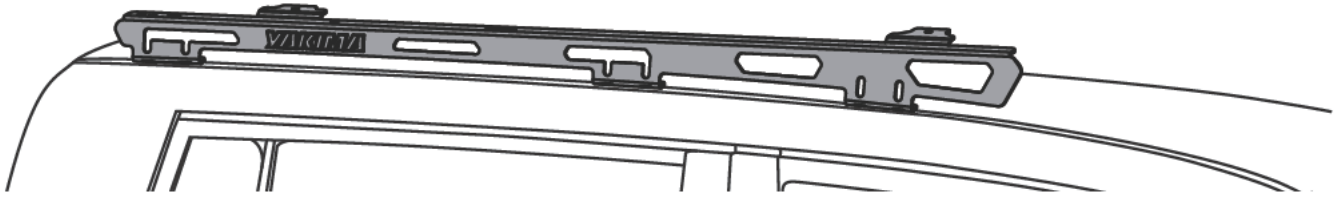
**7****PIVOT BRACKET ASSEMBLIES.**

Retain the 6 mm T-handle ball end allen key and not yet installed pivot brackets, M8 x 20 mm socket head cap screws, M8 nyloc nuts and M8 washers.



These components will be required for mounting your LockNLoad platform to your newly installed RuggedLine.

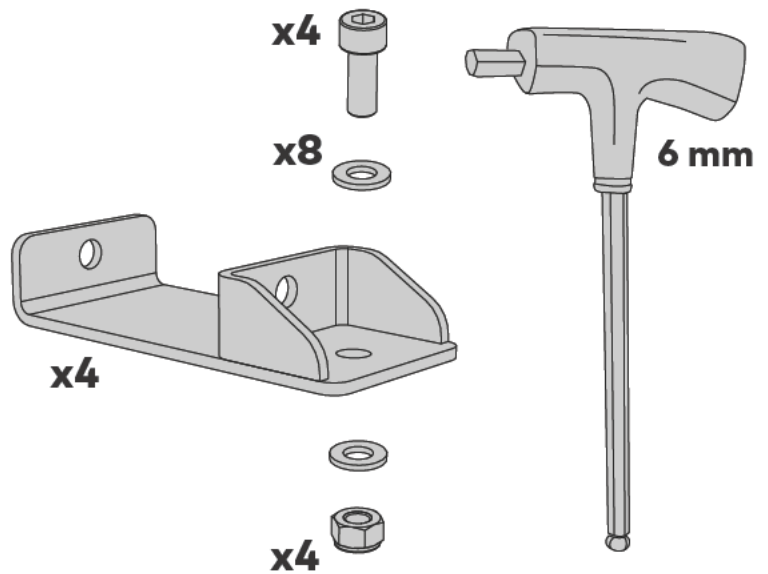

NOW SWITCH TO YOUR LOCKNLOAD PLATFORM INSTRUCTIONS AND CONTINUE FROM THE 'RUGGEDLINE MOUNTING INSTRUCTIONS' PAGE.

YAKIMA®

www.yakima.com.au
www.yakima.co.nz
www.yakima.com
www.yakima.eu

YAKIMA AUSTRALIA PTY LTD

17 Hinkler Court
Brendale, QLD 4500
Australia
1800 143 548

YAKIMA PRODUCTS, INC.

4101 Kruse Way
Lake Oswego, OR
97035-2541
USA
888 925 4621
yakima.com/support

ALL CONTENT SUBJECT TO YAKIMA AUSTRALIA PTY LTD COPYRIGHT © 2022