

MAXIMUM PRODUCT LOAD RATING: 100 kg 

IMPORTANT:

- **LOAD = WEIGHT OF PLATFORM or BARS + MOUNTING SYSTEM + ACCESSORIES + CARGO**
- **PLEASE REFER TO VEHICLE MANUFACTURER SPECIFICATIONS FOR MAX ROOF LOAD CAPACITY OF VEHICLE. THE LOWEST LOAD RATING APPLIES.**
- **OFFROAD RATING: SCAN QR CODE FOR LOCKNLOAD LOAD RATING GUIDE. REDUCTIONS MAY APPLY.**



FIRST TIME INSTALLATION

- Please read instructions carefully before installation.
- Check the contents of kit. Each spine has the last four digits of the kit's part number lasered in. Contact your YAKIMA dealer if any parts appear missing, incorrect or damaged.
- Clean your roof thoroughly prior to fitting the LockNLoad RuggedLine.
- Place these instructions in the vehicle's glove box after installation is complete.



TOOLS REQUIRED:

- Measuring Tape
- Marking pen
- Tin Snips
- 13 mm Spanner
- Flat Head Screwdriver (with tape)

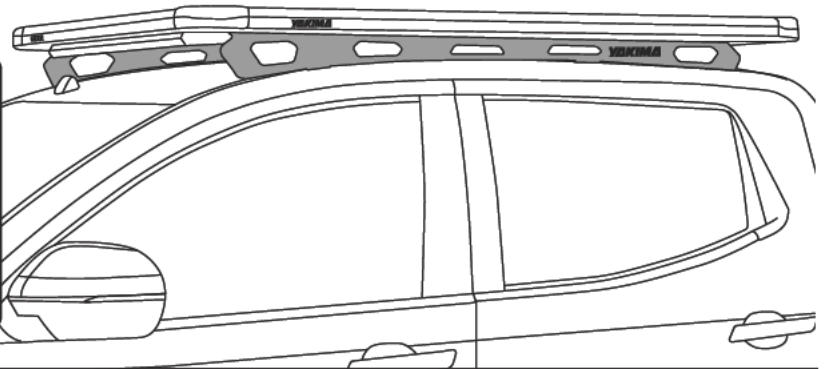

KIT CONTENTS

ITEM	COMPONENT	QTY	ITEM	COMPONENT	QTY
1.	D-Max / BT-50 2020+ Left Spine 1012	x1	7.	M8 Nyloc Nut	x4
2.	D-Max / BT-50 2020+ Right Spine 1012	x1	8.	Foam Adhesive	x8
3.	Pivot Bracket Assembly	x4	9.	Loctite 598 Tube	x1
4.	M8 Socket Head Capscrew 20 mm	x12	10.	4 mm T Handle Ball End Allen Key	x1
5.	M8 Spring Washer	x8	11.	6 mm T Handle Ball End Allen Key	x1
6.	M8 Washer	x16			



**PLATFORM & COMPONENTS SOLD SEPARATELY
RECOMMENDED PLATFORM SIZE IS 'A' (9820337)**

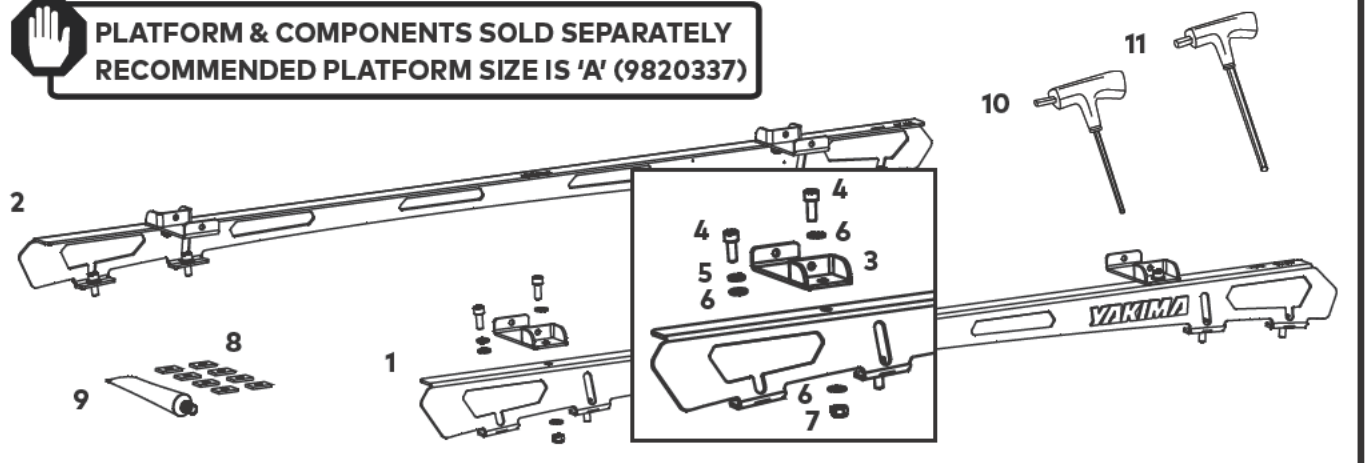

REVEAL MOUNTING POINTS

1 MEASURE FRONT ROOF TRIM

Using a Measuring Tape, measure 226 mm and 418 mm back from the front of the roof trim at edge of windscreen and mark each measurement on trim with a pen.

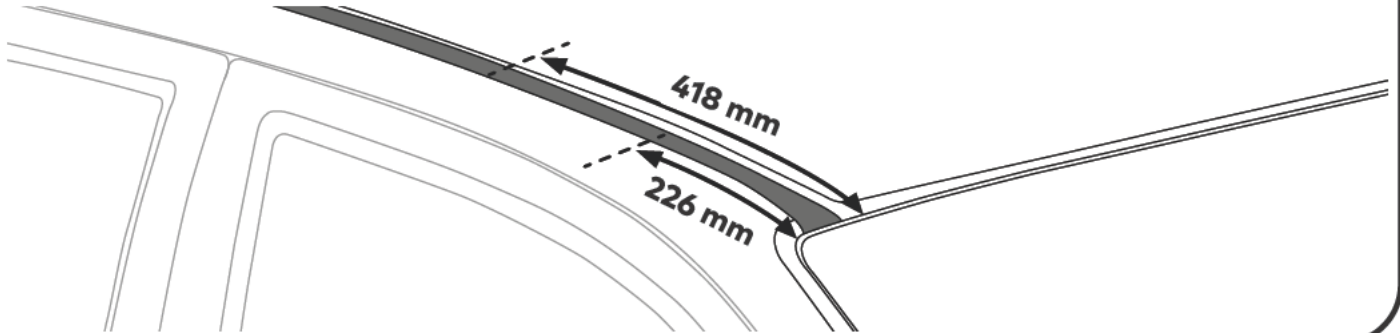

2 MEASURE REAR ROOF TRIM

Using a Measuring Tape, measure 197 mm **from the start of the visible join** in the rear roof trim and mark measurement on trim with a pen.

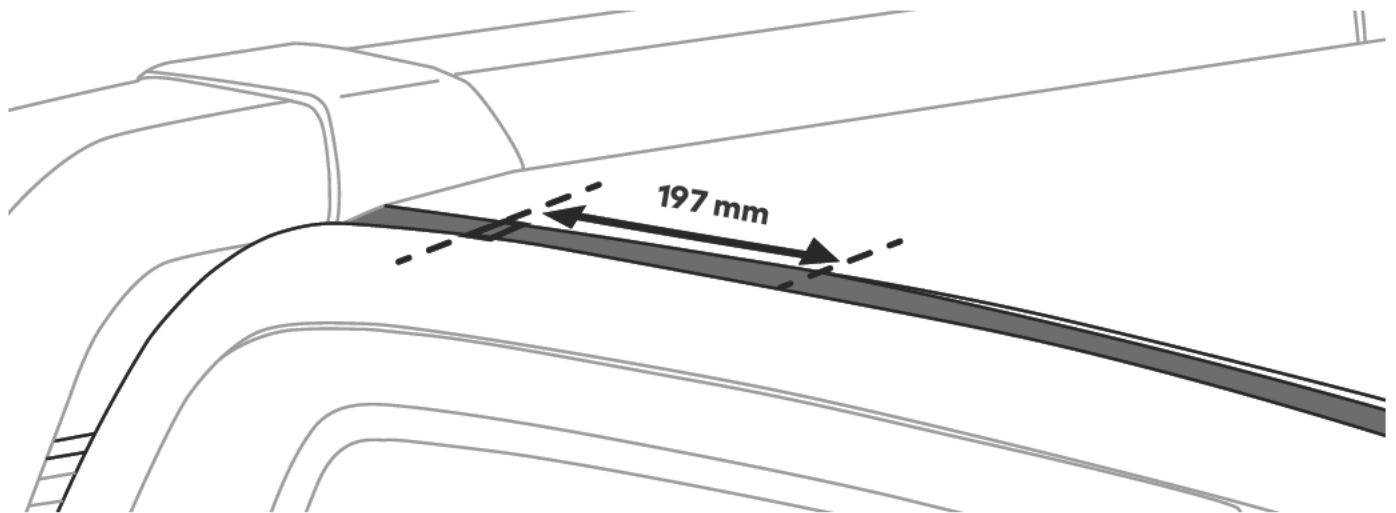

3 CUT ROOF TRIM

Using fingers and a Flat Head Screwdriver (wrap tape around end of Screwdriver to prevent paint scratching), carefully lift up the roof trim and using a pair of Tin Snips, cut the trim at measured sections from Steps 1 and 2.

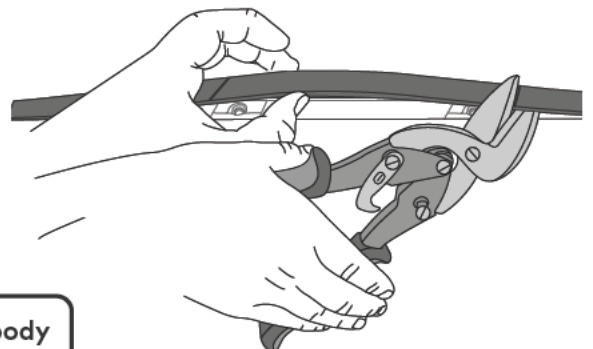
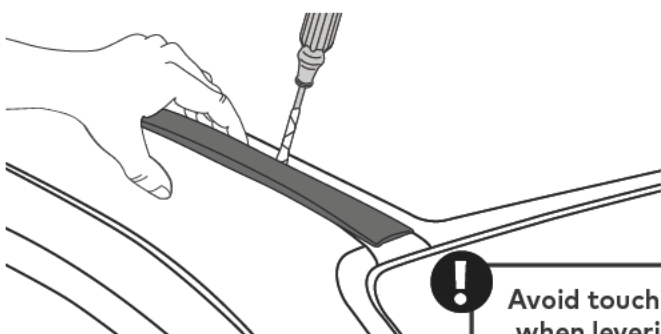

! Avoid touching vehicle body when levering screwdriver.

MOUNTING RUGGEDLINE AND LockNLoad PLATFORM

1 SCRAPE AWAY SEALS

Using a stanley knife, carefully scrape away the paint seals to expose mounting holes.

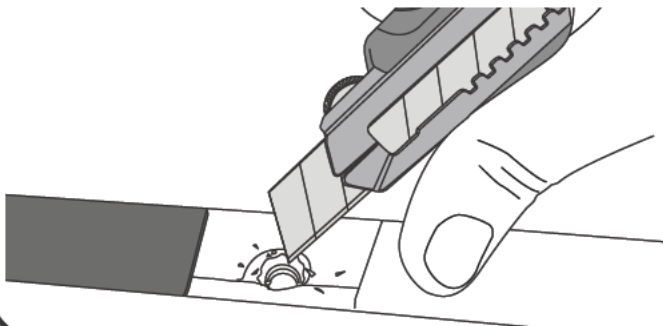

2 AFFIX FOAM ADHESIVE

Carefully apply Foam Adhesive over all metal clips in roof channel, lining up holes in foam with the holes in clips. Apply with adhesive side to vehicle.

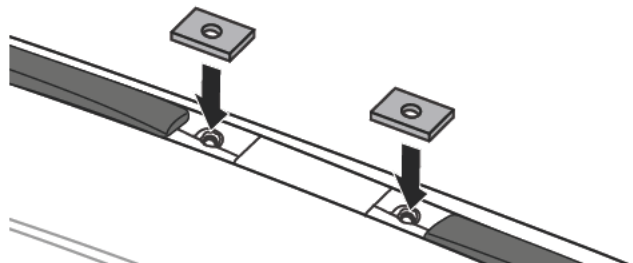

3 APPLY LOCTITE

Liberaly apply the supplied Loctite to the inside surface and on top of each hole **on one side of vehicle**.

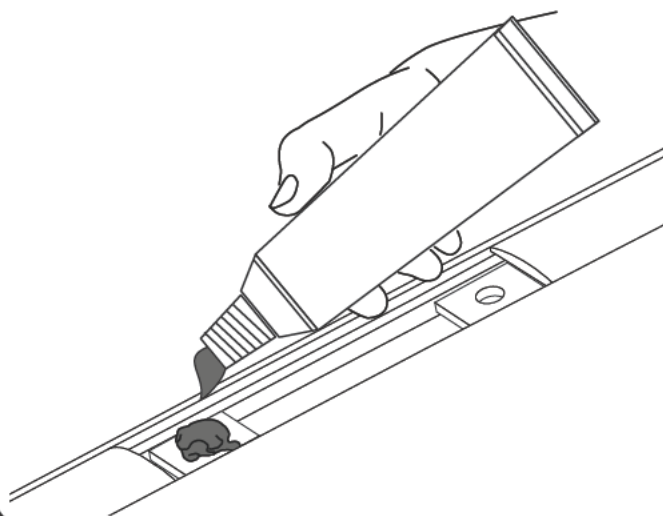

4 ASSEMBLE PIVOT BRACKET TO RUGGEDLINE

Assemble Pivot Bracket and M8 hardware as pictured. Complete this for the 2 mounting holes on top of the RuggedLine Spine.

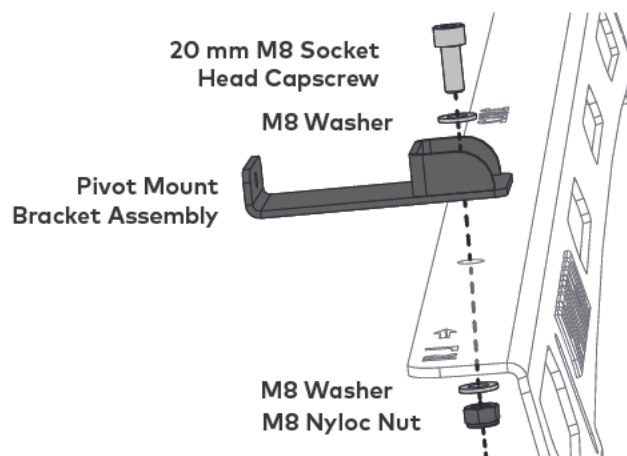

5 SECURE PIVOT BRACKET ASSEMBLIES

Tighten all Capscrews with the provided 6 mm T Handle Ball End Allen Key, and all Nuts with a 13 mm Spanner or a suitable Torque Wrench.

Ensure all Capscrews and Nuts are tightened to 7 Nm.

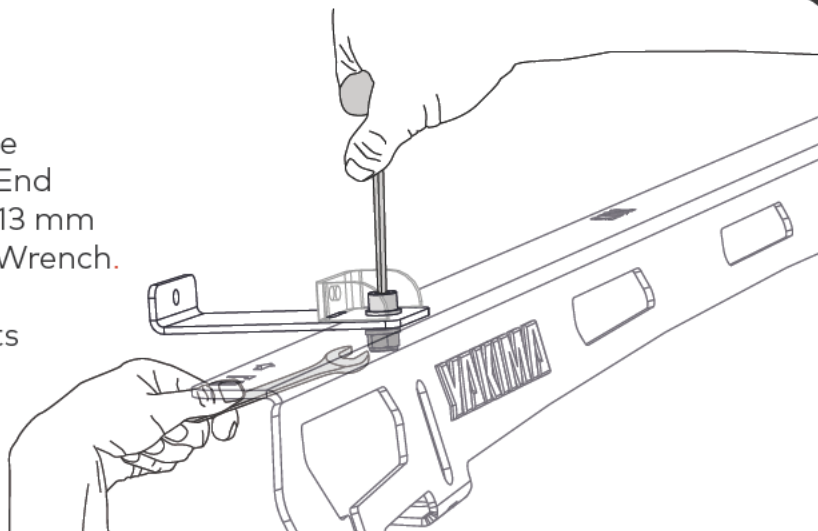

6**POSITION RUGGEDLINE ON VEHICLE ROOF**

Referring to the left-right orientation on top of each Spine, carefully place one side of the RuggedLine onto vehicle roof as shown. Line up the mounting holes on the bottom tabs to those exposed on the roof. The tabs are to face in towards the vehicle.

Front of vehicle

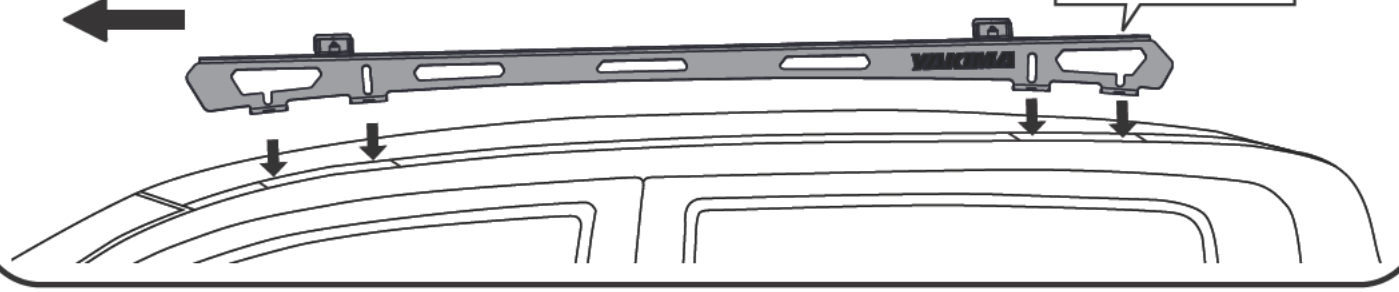
**7****ASSEMBLE RUGGEDLINE HARDWARE**

Assemble the 20 mm M6 Socket Head Capscrew, M6 Spring Washer and Washer as shown and place into mounting holes on bottom tabs of RuggedLine. Ensure hardware and holes align with the holes on roof.

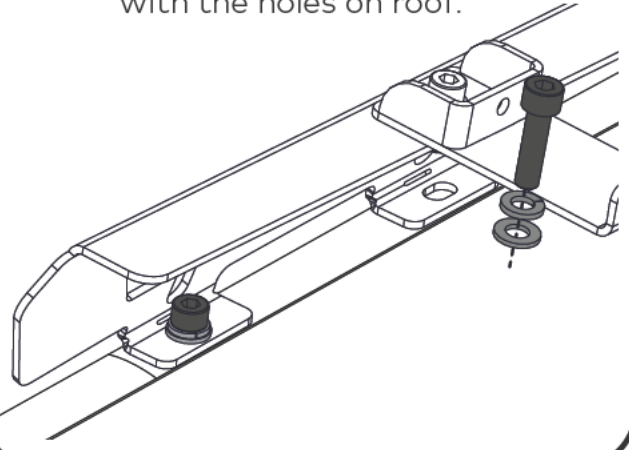
**8****TIGHTEN RUGGEDLINE HARDWARE**

Using the 6 mm T Handle Ball End Allen Key, and avoiding damage to the powder coat, start to carefully secure the RuggedLine by tightening the M8 Socket Head Capscrews to 4 Nm. into the mounting holes in roof.

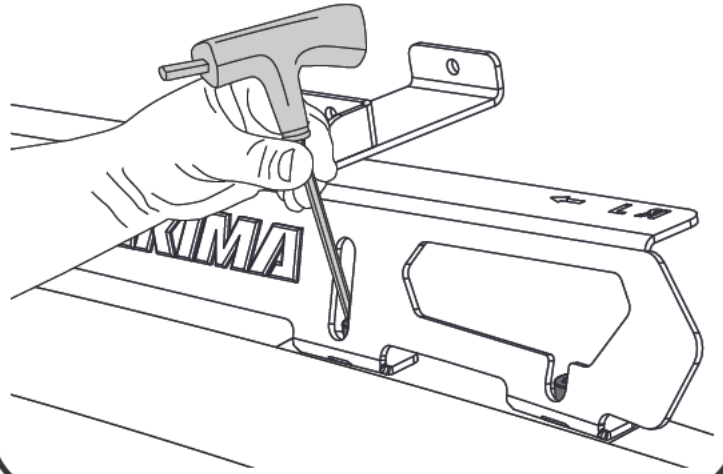
**9****REPEAT STEPS TO OPPOSITE SIDE**

Repeat steps 1-3 on page 2 and steps 1-8 on pages 3 & 4 for securing opposite side of RuggedLine Spine.

Ensure both Spines are securely positioned on vehicle roof. Check each screw is secure before proceeding to install LockNLoad Platform to RuggedLine Spines.

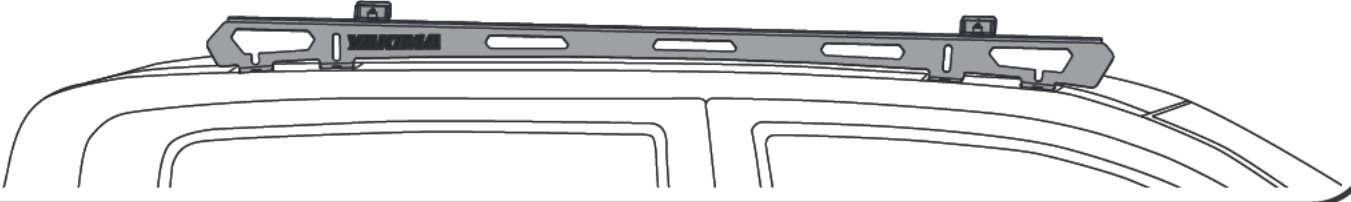

10**INSTALL PLATFORM PIVOT MOUNTS**

From the LockNLoad Platform kit (sold separately), position Pivot Mounts into each Pivot Bracket Assembly, lining up the rivnut holes on the Mounts with the holes on the brackets.

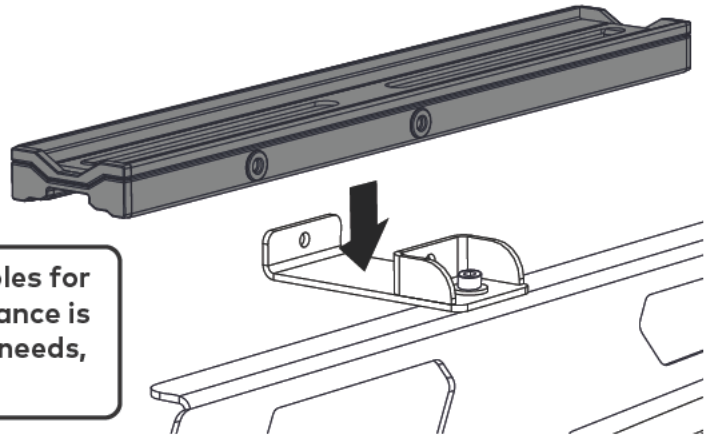
**!**

Where possible, always use the centre holes for attaching to Pivot Bracket. If extra clearance is needed due to Platform-to-roof fitment needs, the offset holes can be used.

11**SECURE PLATFORM PIVOT MOUNTS**

Secure all Platform Pivot Mounts with 2x 16 mm M6 Capscrews with Washer from LockNLoad Platform kit as shown.

Tighten all Capscrews to 4 Nm with the provided 4 mm Ball End Allen Key or a suitable Torque Wrench.

NOTE - The Pivot Mount assembly will still have movement after securing which is intended.

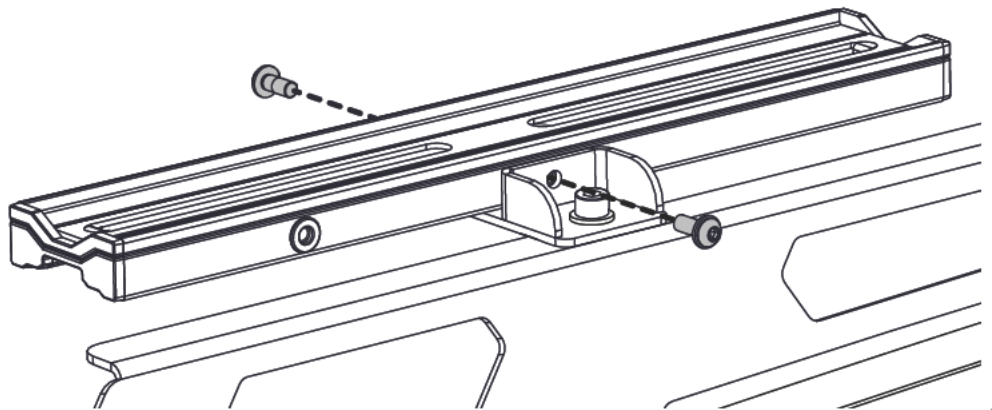
**!**

NOW SWITCH TO YOUR LockNLoad PLATFORM INSTRUCTIONS AND CONTINUE FROM THE 'VEHICLE MOUNTING INSTRUCTIONS' PAGE.

YAKIMA

www.yakima.com.au

www.yakima.co.nz

www.yakima.com

www.yakima.eu

YAKIMA AUSTRALIA PTY LTD

17 Hinkler Court
Brendale, QLD 4500
Australia
1800 143 548

YAKIMA PRODUCTS, INC.

4101 Kruse Way
Lake Oswego, OR
97035-2541
USA
888 925 4621

ALL CONTENT SUBJECT TO YAKIMA AUSTRALIA PTY LTD COPYRIGHT © 2021