

MAXIMUM PRODUCT LOAD RATING: 100 kg 

IMPORTANT:

- **LOAD = WEIGHT OF PLATFORM or BARS + MOUNTING SYSTEM + ACCESSORIES + CARGO**
- **PLEASE REFER TO VEHICLE MANUFACTURER SPECIFICATIONS FOR MAX ROOF LOAD CAPACITY OF VEHICLE. THE LOWEST LOAD RATING APPLIES.**
- **OFFROAD RATING: SCAN QR CODE FOR LOCKNLOAD LOAD RATING GUIDE. REDUCTIONS MAY APPLY.**



FIRST TIME INSTALLATION

- Please read instructions carefully before installation.
- Check the contents of kit. Each spine has the last four digits of the kit's part number lasered in.
- Contact your YAKIMA dealer if any parts appear missing, incorrect or damaged.
- Clean your roof thoroughly prior to fitting the LockNLoad RuggedLine.
- Place these instructions in the vehicle's glove box after installation is complete.



TOOLS REQUIRED:

- 10 mm Socket Wrench
- 13 mm Spanner

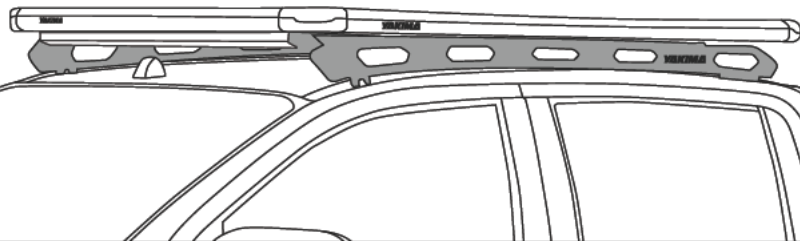

KIT CONTENTS

ITEM	COMPONENT	QTY	ITEM	COMPONENT	QTY
1.	Wildtrak Left Spine 1011	x1	9.	M6 Nyloc Nut	x8
2.	Wildtrak Right Spine 1011	x1	10.	M6 Button Head Capscrew	x2
3.	Pivot Bracket Assembly	x4	11.	Foam Adhesive	x6
4.	M8 Socket Head Capscrew 20 mm	x4	12.	Loctite 598 Tube	x1
5.	M8 Washer	x8	13.	4 mm T Handle Ball End Allen Key	x1
6.	M8 Nyloc Nut	x4	14.	5 mm T Handle Ball End Allen Key	x1
7.	M6 Socket Head Capscrew 25 mm	x6	15.	6 mm T Handle Ball End Allen Key	x1
8.	M6 Washer	x14			



**PLATFORM & COMPONENTS SOLD SEPARATELY
RECOMMENDED PLATFORM SIZE IS 'A' (9820337)**

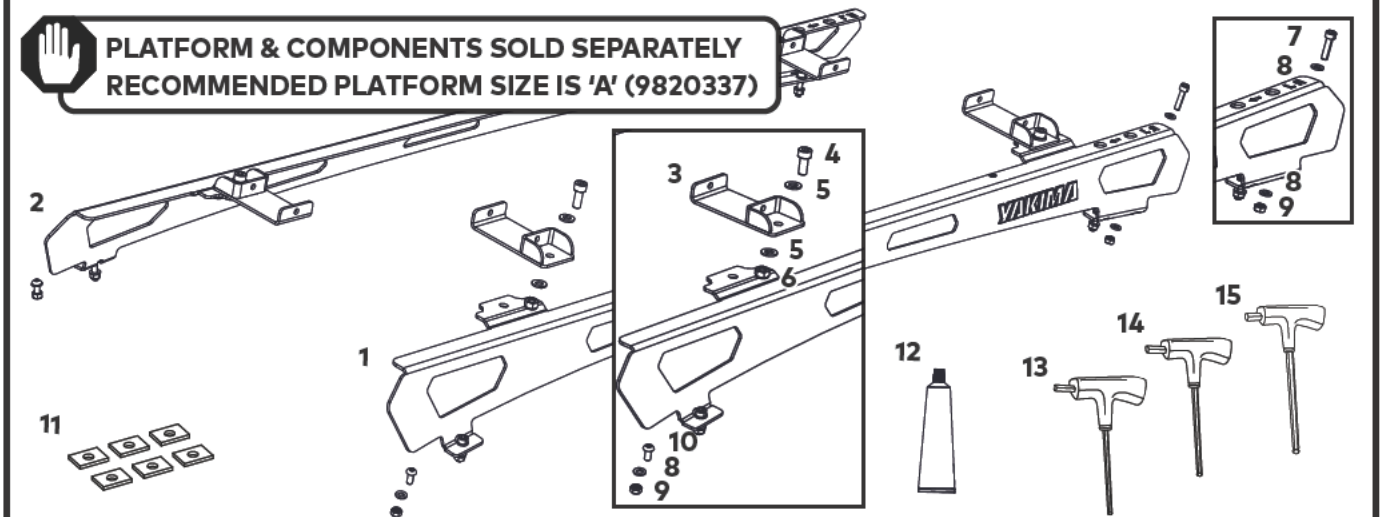

REMOVING FACTORY RAISED ROOF RAILS

1 REMOVE RAIL HARDWARE

Before the factory roof rails can be removed, you will need to arrange for the roof lining to be carefully removed to provide access to the rail nuts. These are only accessible from the underside of the roof.

Once the lining has been removed, unscrew the factory nuts to remove the roof rails. There are 2x nuts for each rail end to be removed as shown.

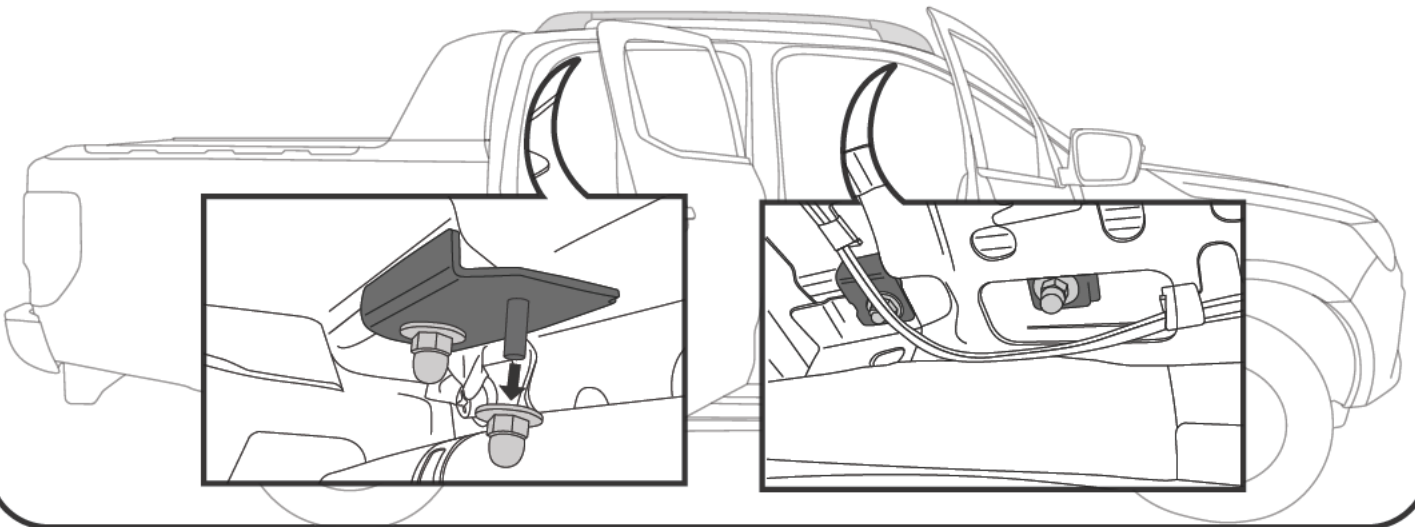

2 REMOVE RAILS

Carefully lift roof rails directly upwards and remove from the roof.

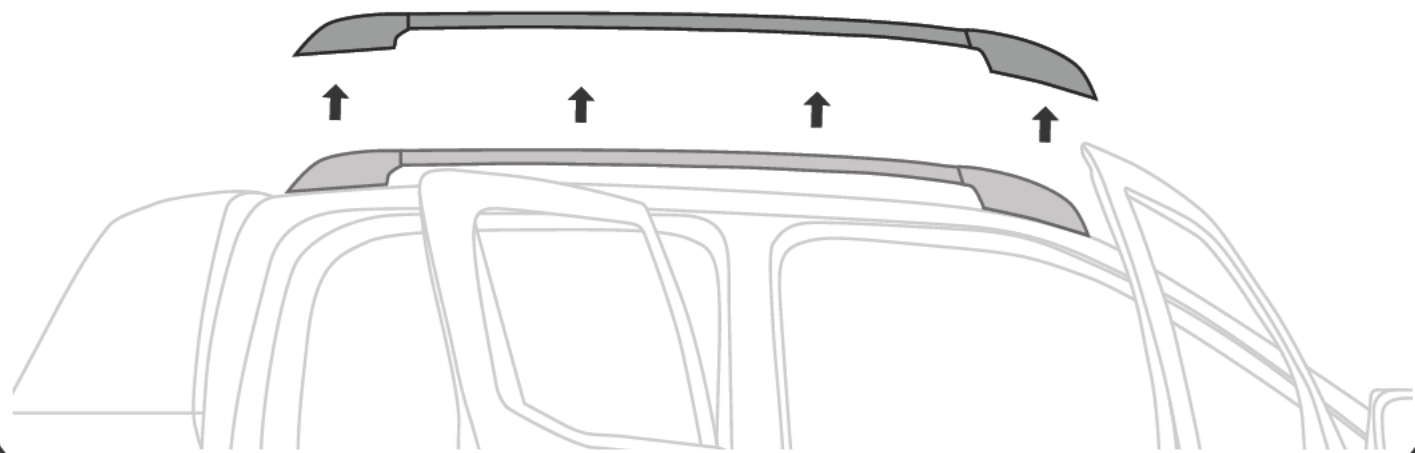

3 CLEAN ROOF

Wipe clean any dirt that may have built up in and around all mounting holes.

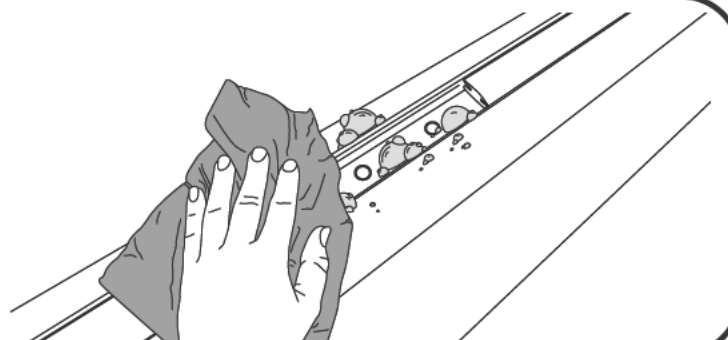

MOUNTING RUGGEDLINE AND LOCKLOAD PLATFORM

1 AFFIX FOAM ADHESIVE

Apply Foam Adhesive over all 4 mounting holes at the rear of vehicle, and the rear most holes only at the front of vehicle. Apply with adhesive side to vehicle.

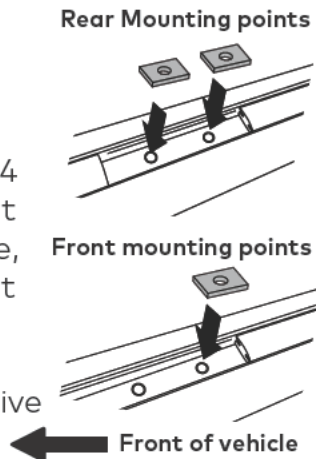

2 APPLY LOCTITE

Liberally apply the supplied Loctite to the inside surface and on top of each hole **on one side of vehicle.**

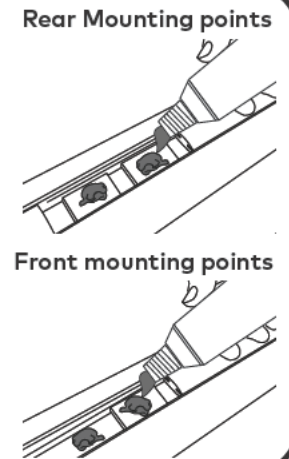

3 ASSEMBLE PIVOT BRACKET TO RUGGEDLINE

Assemble Pivot Bracket and M8 hardware as pictured. Complete this for the 2 mounting holes on top of the RuggedLine Spine.

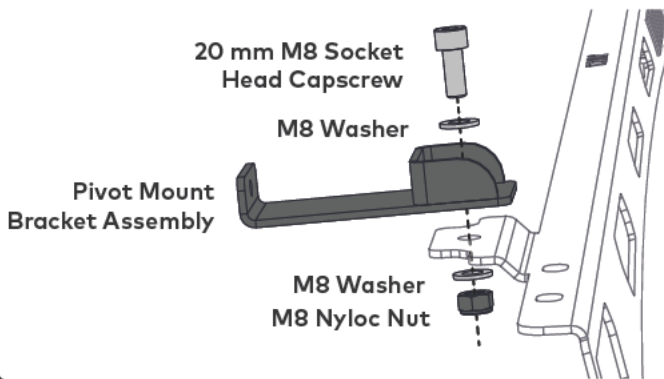

4 SECURE PIVOT BRACKET ASSEMBLIES

Tighten all Capscrews with the provided 6 mm T Handle Ball End Allen Key, and all Nuts with a 13 mm Spanner or a suitable Torque Wrench.

Ensure all Capscrews and Nuts are tightened to 7 Nm.

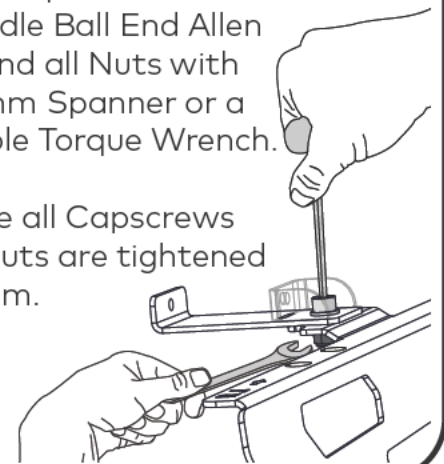

! FACTORY SNORKEL

RuggedLine can be installed in conjunction with a factory Snorkel. The Ruggedline Spine can sit on top of the Snorkel bracket.

5 POSITION RUGGEDLINE ON VEHICLE ROOF

Referring to the left-right orientation on top of each Spine, carefully place one side of the RuggedLine onto vehicle roof as shown. Line up the mounting holes on the bottom tabs to those exposed on the roof.

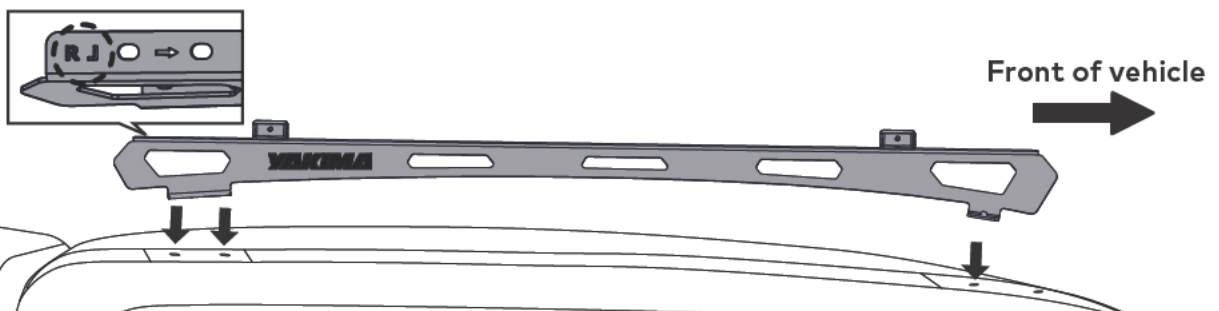

6**ASSEMBLE RUGGEDLINE HARDWARE**

Assemble the 25 mm M6 Socket Head Capscrew and M6 Washer as shown and place into all 3 mounting holes on bottom tabs of RuggedLine. Ensure hardware and holes align with the holes on roof.

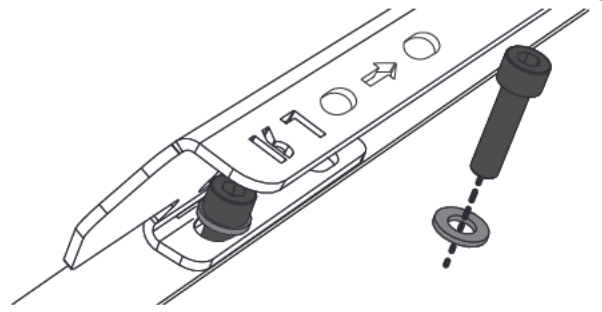
**7****TIGHTEN RUGGEDLINE HARDWARE**

Using the 6 mm T Handle Ball End Allen Key, start to carefully secure the RuggedLine by tightening the M6 Socket Head Capscrews to 4 Nm into the mounting holes in roof.

Using a 10 mm Socket Wrench, secure from the inside of the roof using an M6 Washer and M6 Nyloc Nut.

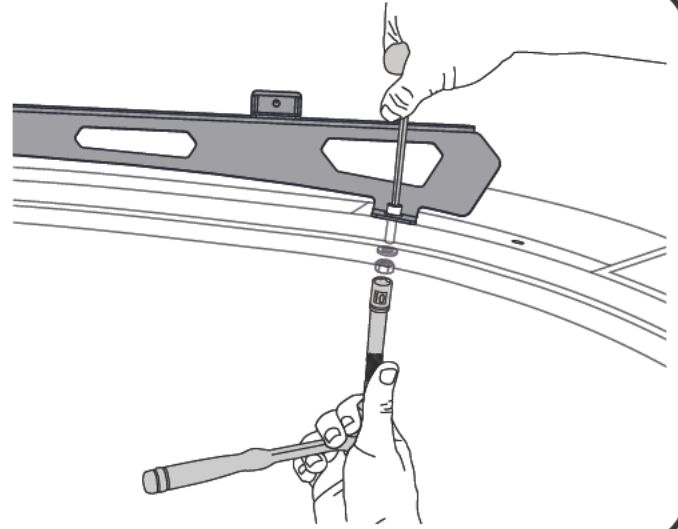
**8****FILL IN FRONT HOLE**

Using a 1x M6 Button Head Capscrew, 1x M6 Washer and 1x M6 Nyloc Nut, repeat the process to fill in the front hole in vehicle roof.

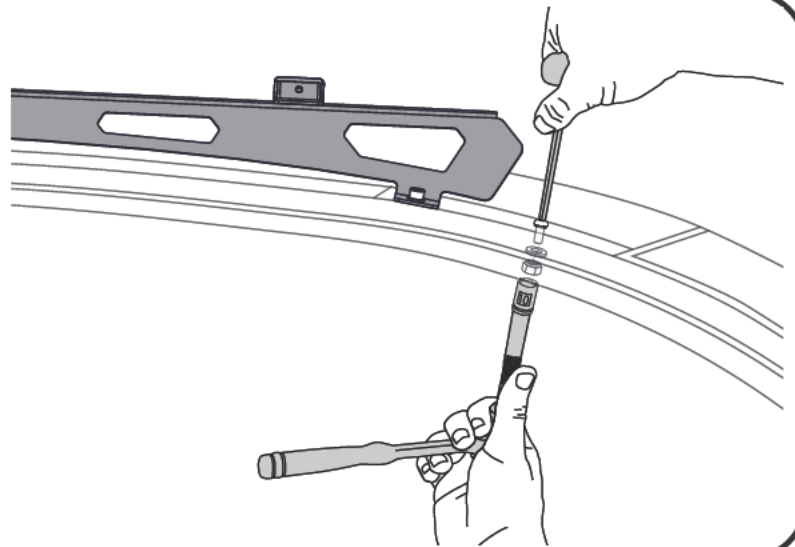
**9****REPEAT STEPS TO OPPOSITE SIDE**

Repeat steps 2-8 for securing opposite side of RuggedLine Spine.

Ensure both Spines are securely positioned on vehicle roof. Check each screw is secure before proceeding to install LockNLoad Platform to RuggedLine Spines.

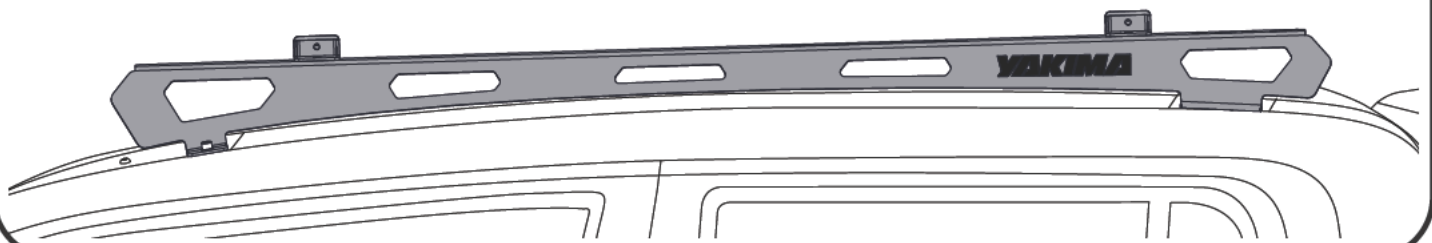

10**REPLACE ROOF LINING**

Replace the vehicle roof lining removed at the beginning of installation.

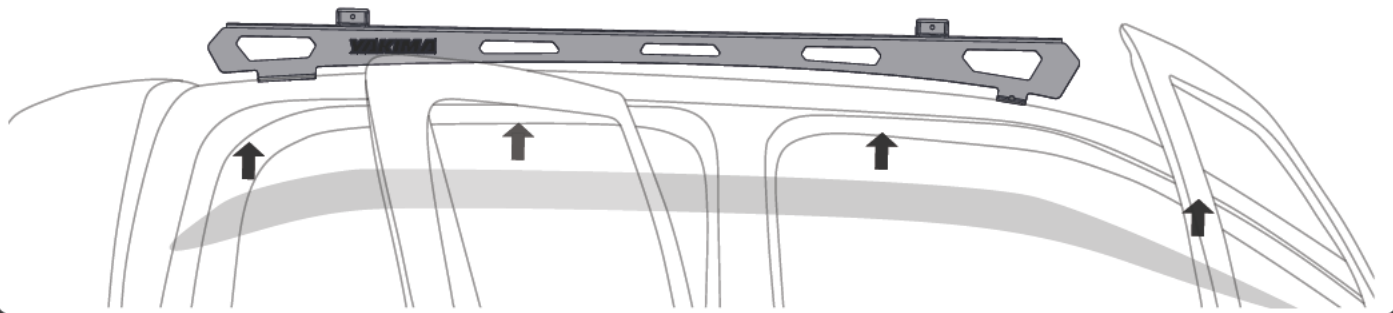
**11****INSTALL PLATFORM PIVOT MOUNTS**

From the LockNLoad Platform kit (sold separately), position Pivot Mounts into each Pivot Bracket Assembly, lining up the rivnut holes on the Mounts with the holes on the brackets.

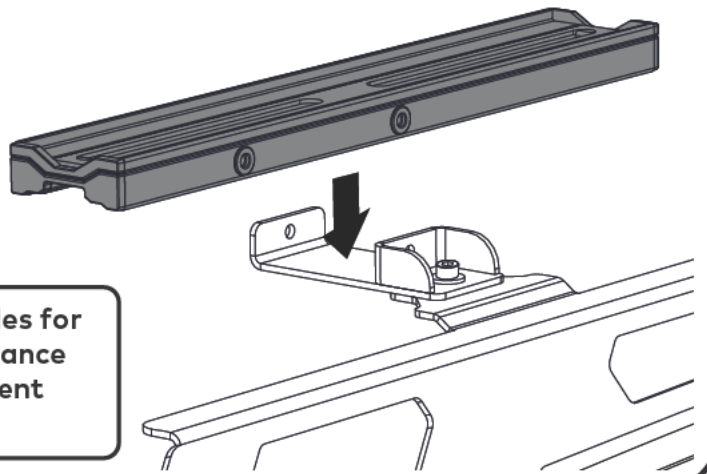

Where possible, always use the centre holes for attaching to Pivot Bracket. If extra clearance is needed due to Platform-to-roof fitment needs, the offset holes can be used.

12**SECURE PLATFORM PIVOT MOUNTS**

Secure all Platform Pivot Mounts with 2x 16 mm M6 Capscrews with Washer from LockNLoad Platform kit as shown.

Tighten all Capscrews to 4 Nm with the provided 4 mm Ball End Allen Key or a suitable Torque Wrench.

NOTE - The Pivot Mount assembly will still have movement after securing which is intended.

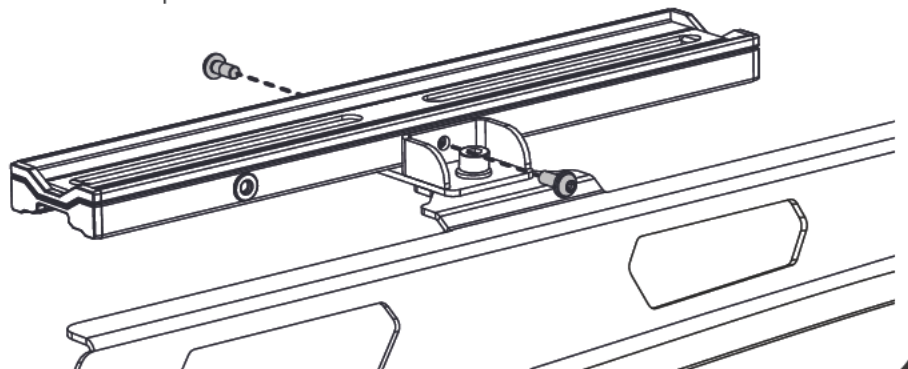

NOW SWITCH TO YOUR LOCKNLOAD PLATFORM INSTRUCTIONS AND CONTINUE FROM THE 'VEHICLE MOUNTING INSTRUCTIONS' PAGE.



www.yakima.com.au
www.yakima.co.nz
www.yakima.com
www.yakima.eu

YAKIMA AUSTRALIA PTY LTD

17 Hinkler Court
Brendale, QLD 4500
Australia
1800 143 548

YAKIMA PRODUCTS, INC.

4101 Kruse Way
Lake Oswego, OR
97035-2541
USA
888 925 4621

ALL CONTENT SUBJECT TO YAKIMA AUSTRALIA PTY LTD COPYRIGHT © 2022