

MAXIMUM PRODUCT LOAD RATING: 150 kg 

IMPORTANT:

- **LOAD = WEIGHT OF PLATFORM or BARS + MOUNTING SYSTEM + ACCESSORIES + CARGO**
- **PLEASE REFER TO VEHICLE MANUFACTURER SPECIFICATIONS FOR MAX ROOF LOAD CAPACITY OF VEHICLE. THE LOWEST LOAD RATING APPLIES.**
- **OFFROAD RATING: SCAN QR CODE FOR LOCKNLOAD LOAD RATING GUIDE. REDUCTIONS MAY APPLY.**



FIRST TIME INSTALLATION

- Please read instructions carefully before installation.
- Check the contents of kit. Each spine has the last four digits of the kit's part number lasered in. Contact your YAKIMA dealer if any parts appear missing, incorrect or damaged.
- Clean your roof thoroughly prior to fitting the LockNLoad RuggedLine.
- Place these instructions in the vehicle's glove box after installation is complete.



TOOLS REQUIRED:

- 10 mm Socket Wrench
- 13 mm Spanner
- Flat Head Screwdriver (with tape)
- 10 mm Breaker Bar (optional)
- Rattle Gun (optional)

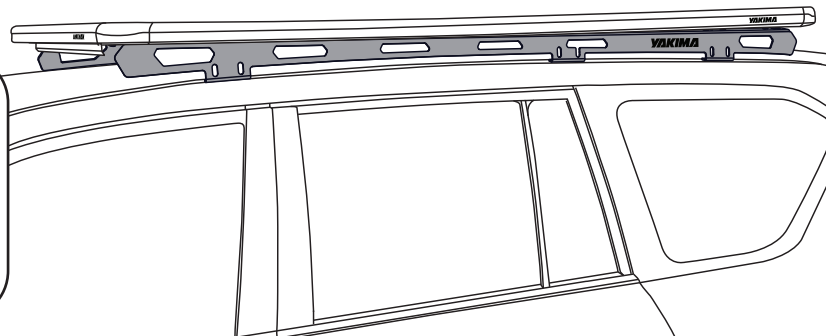

KIT CONTENTS

ITEM	COMPONENT	QTY	ITEM	COMPONENT	QTY
1.	Prado 120 Left Spine 1009	x1	7.	M8 Socket Head Capscrew 30 mm	x12
2.	Prado 120 Right Spine 1009	x1	8.	M8 Nyloc Nut	x6
3.	Pivot Bracket Assembly	x6	9.	Foam Adhesive	x12
4.	M8 Socket Head Capscrew 20 mm	x6	10.	Loctite 598 Tube	x1
5.	M8 Washer	x24	11.	6 mm T Handle Ball End Allen Key	x1
6.	M8 Spring Washer	x12	12.	4 mm T Handle Ball End Allen Key	x1



**PLATFORM & COMPONENTS SOLD SEPARATELY
RECOMMENDED PLATFORM SIZE IS 'E' (9820341)**

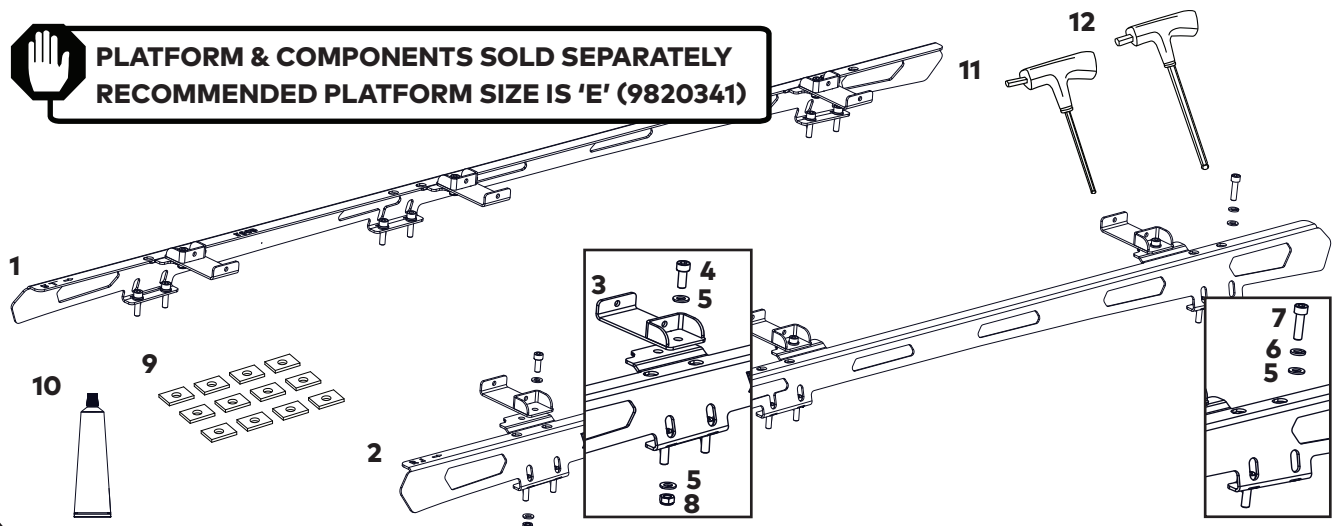

REMOVING FIXED POINT COVERS (BARE ROOF)

1 REMOVE FIXED POINT HARDWARE

If your vehicle is not fitted with factory roof rails, remove all fixed-point covers.

Remove bolts, washers and brackets from the vehicle's fixed points.

Store removed hardware away in a safe place.

Now proceed to page 5 - MOUNTING RUGGEDLINE AND LOCKLOAD PLATFORM

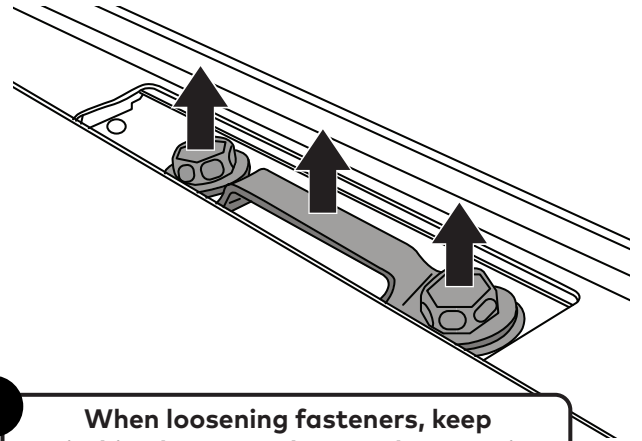

! When loosening fasteners, keep switching between them to drop tension progressively. If not, the nutplate inside the roof cavity may come loose.

REMOVING FACTORY RAISED ROOF RAILS

1a UNCLIP PLASTIC RAIL COVERS

Using a Flat Head Screwdriver with tape wrapped around the blade, release the plastic rail end covers by carefully levering the Screwdriver downwards and squeezing the covers until the outer clips release.

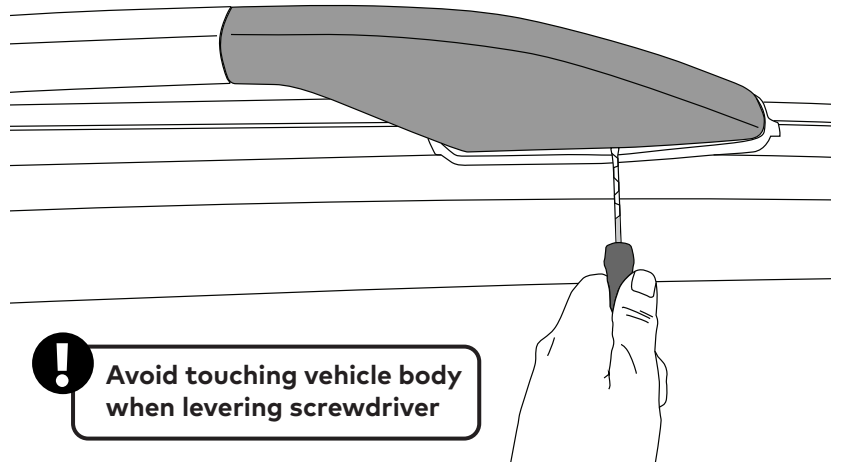

! Avoid touching vehicle body when levering screwdriver

1b UNCLIP PLASTIC RAIL COVERS

Once the outer clips are freed, press the cover towards the car's centre to release the clips on the inside face.

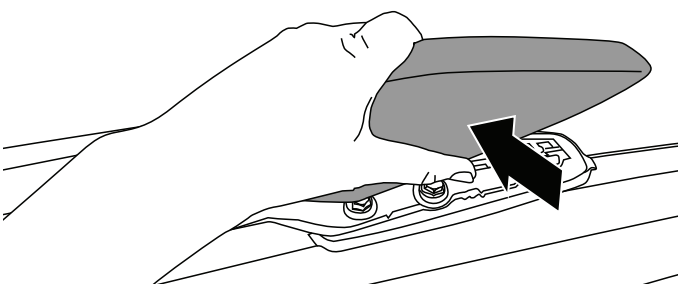

2 REMOVE PLASTIC RAIL COVERS

Lift the detached cover and slide away from the rail.

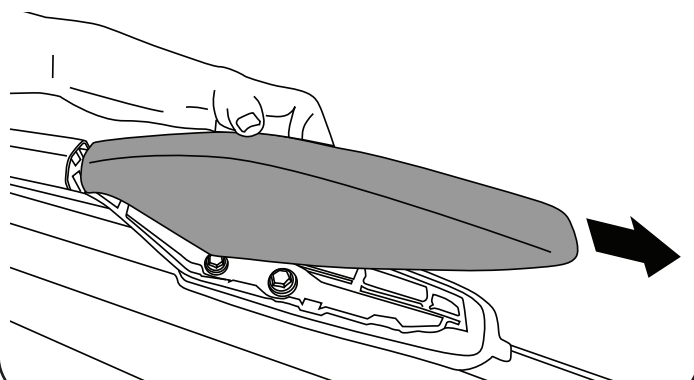

3 REMOVE COVER HARDWARE

Remove exposed hardware using a 10 mm Socket Wrench or Breaker Bar.

Complete steps 1a - 3 for front and rear covers and repeat on opposite side of vehicle.

Store removed hardware away in a safe place.

NOTE - a Rattle Gun may be required if the factory Loctite is too difficult to break loose.

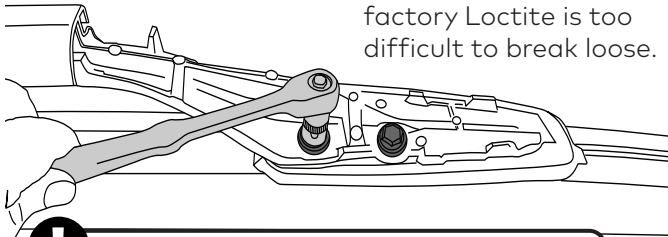

! When loosening fasteners, switch between them to drop tension progressively. If not, the nutplate inside the roof cavity may come loose.

4 UNCLIP CENTER RAIL COVERS

Using the Flat Head Screwdriver, position it between the center rail pillar and plastic cover. Pry the cover from the rail leg until the inner plastic clip releases.

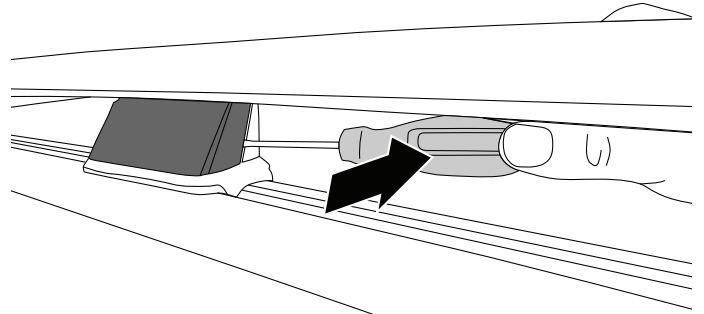

5 REMOVE CENTER RAIL CASES

Once the clip releases, pull to remove the cover.

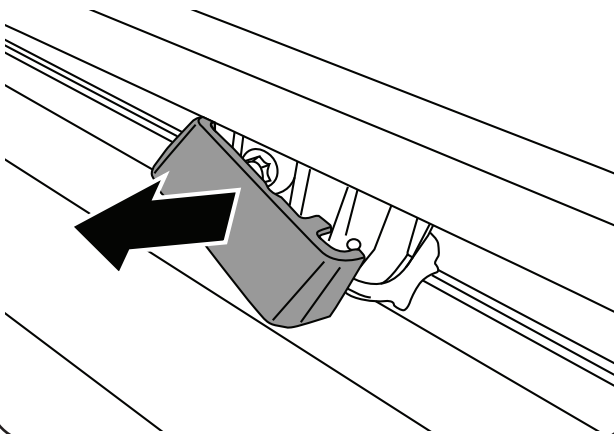

6 REMOVE CENTER RAIL HARDWARE

Using a 10 mm Socket Wrench, remove the bolt from the center rail mounting point.

Complete steps 4 - 6 on opposite side of vehicle.

Store removed hardware away in a safe place.

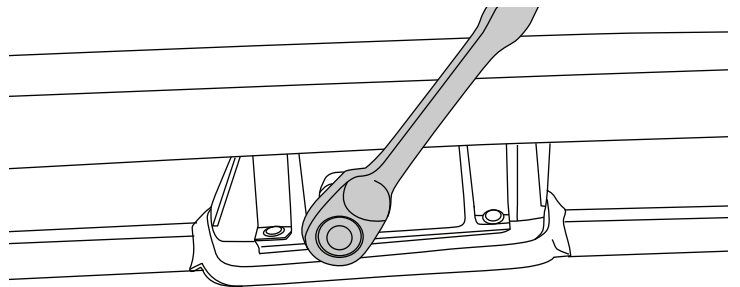

7 REMOVE RAILS

Lift roof rails upwards and carefully remove from the roof.

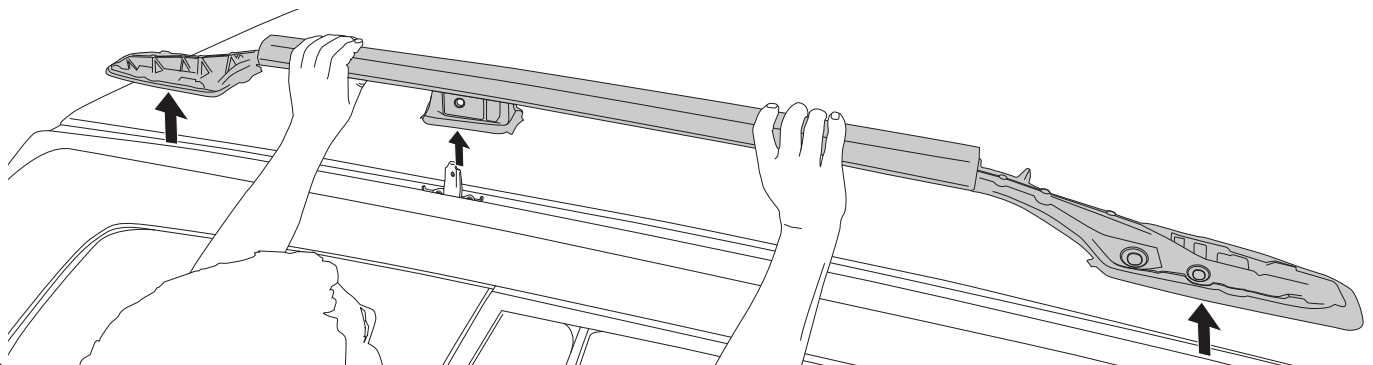

8 REMOVE CENTER MOUNTING HARDWARE

Using a 10 mm Socket Wrench, remove the remaining hardware as pictured from the centre mounting points.

Store removed hardware away in a safe place.

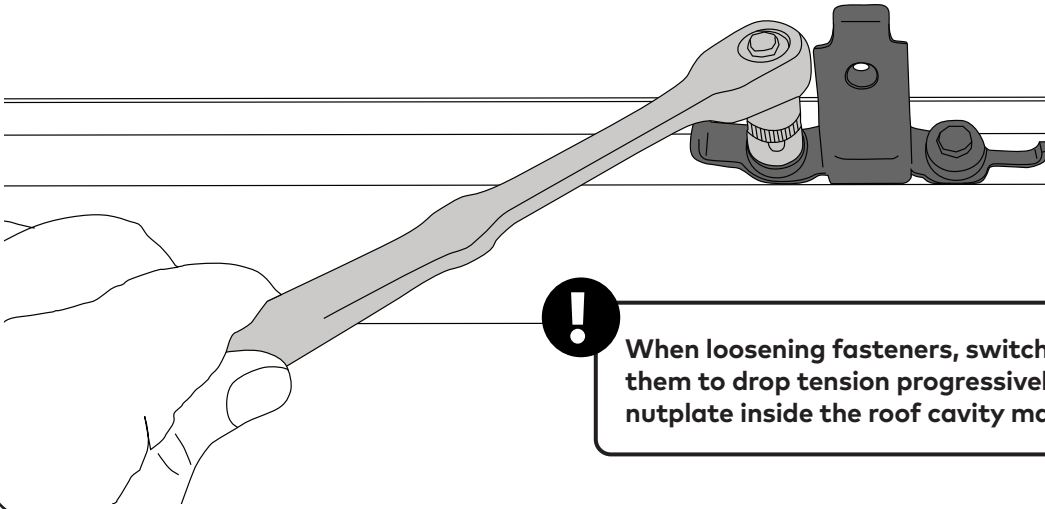

When loosening fasteners, switch between them to drop tension progressively. If not, the nutplate inside the roof cavity may come loose.

9 CLEAN ROOF

Wipe clean any dirt that may be present in and around the mounting holes.

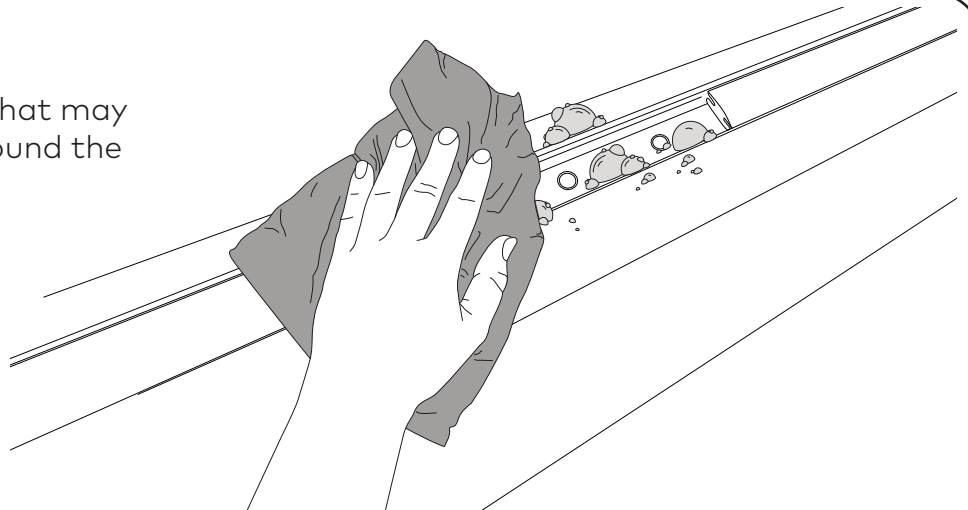

MOUNTING RUGGEDLINE AND LOCKNLOAD PLATFORM

1 AFFIX FOAM ADHESIVE

Apply Foam Adhesive over all 12 plastic tubes in the vehicle's mounting holes, with adhesive side to vehicle.

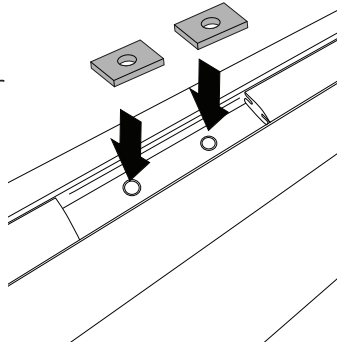

2 APPLY LOCTITE

Liberally apply the supplied Loctite to the inside surface and on top of each hole **on one side of vehicle.**

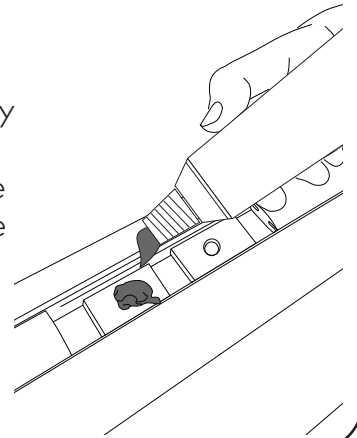

3 ASSEMBLE PIVOT BRACKET TO RUGGEDLINE

Assemble Pivot Bracket and M8 hardware as pictured. Complete this for the 3 tabs on top of the RuggedLine Spine.

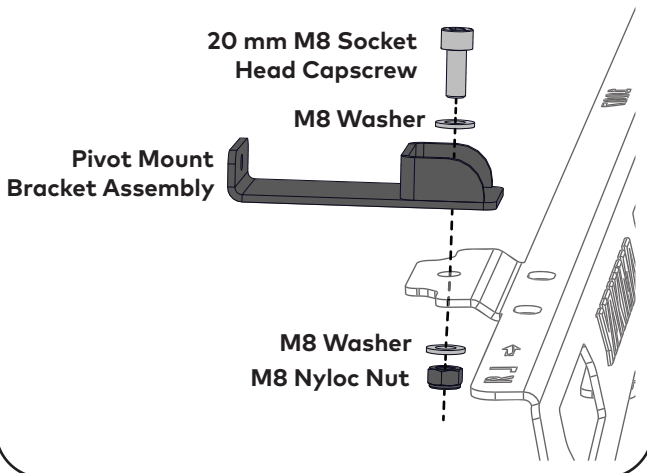

4 SECURE PIVOT BRACKET ASSEMBLIES

Tighten all Capscrews with the provided 6 mm T Handle Ball End Allen Key, and all Nuts with a 13 mm Spanner or a suitable Torque Wrench.

Ensure all Capscrews and Nuts are tightened to 7 Nm.

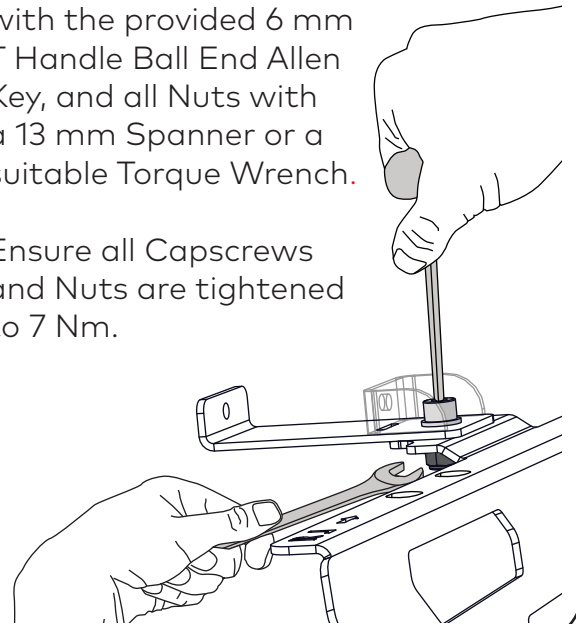

5 POSITION RUGGEDLINE ON VEHICLE ROOF

Referring to the left-right orientation on top of each Spine, carefully place one side of the RuggedLine onto vehicle roof as shown. Line up the mounting holes on the bottom tabs to those exposed on the roof. The tabs are to face in towards the vehicle.

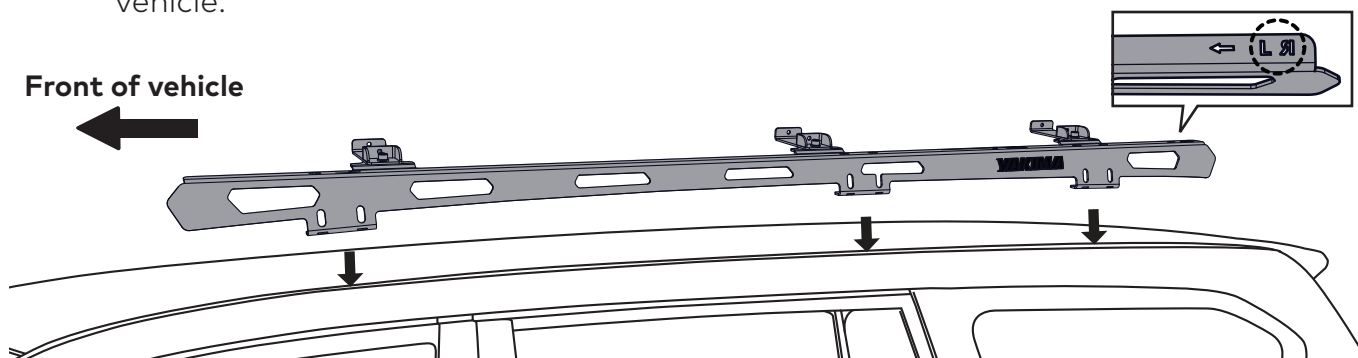

6 ASSEMBLE RUGGEDLINE HARDWARE

Assemble the 30 mm M8 Socket Head Capscrew, M8 Spring Washer and Washer as shown and place into mounting holes on bottom tabs of RuggedLine. Ensure hardware and holes align with the holes on roof.

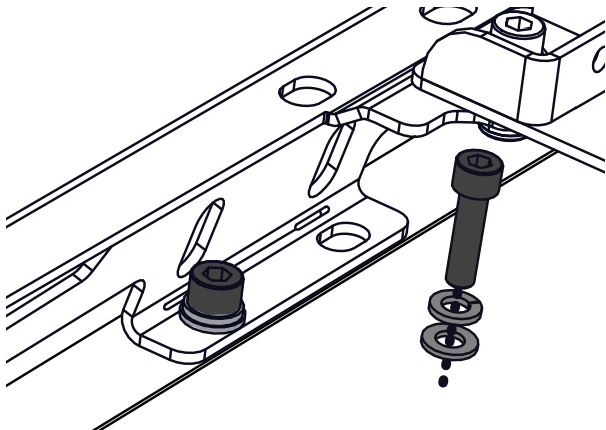

7 TIGHTEN RUGGEDLINE HARDWARE

Using the 6 mm T Handle Ball End Allen Key, and avoiding damage to the powder coat, start to carefully secure the RuggedLine by tightening the M8 Socket Head Capscrews to 7 Nm into the mounting holes in roof.

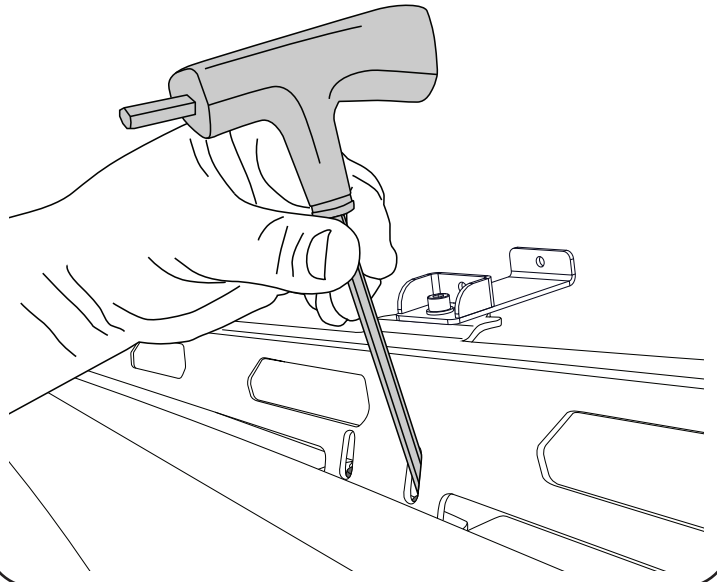

8 REPEAT STEPS TO OPPOSITE SIDE

Repeat steps 2-7 for securing opposite side of RuggedLine Spine.

Ensure both Spines are securely positioned on vehicle roof. Check each screw is secure before proceeding to install LockNLoad Platform to RuggedLine Spines.

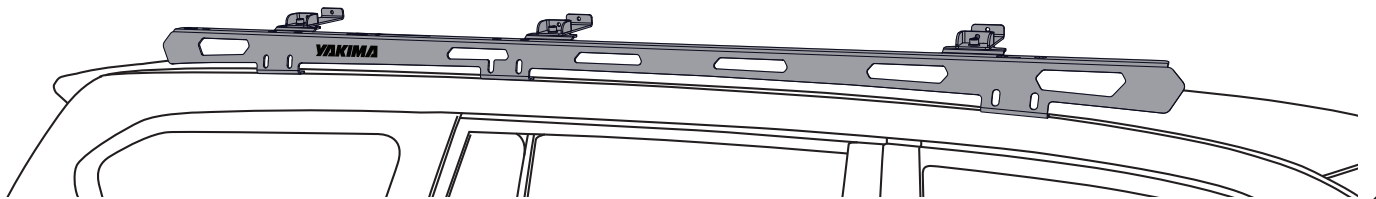

9 INSTALL PLATFORM PIVOT MOUNTS

From the LockNLoad Platform kit (sold separately), position Pivot Mounts into each Pivot Bracket Assembly, lining up the rivnut holes on the Mounts with the holes on the brackets.

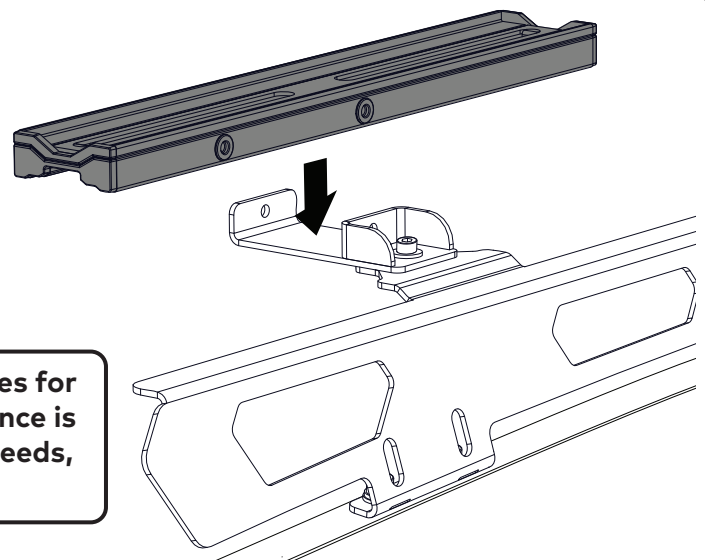

! Where possible, always use the centre holes for attaching to Pivot Bracket. If extra clearance is needed due to Platform-to-roof fitment needs, the offset holes can be used.

10**SECURE PLATFORM PIVOT MOUNTS**

Secure all Platform Pivot Mounts with 2x 16 mm M6 Capscrews with Washer from LockNLoad Platform kit as shown.

Tighten all Capscrews to 4 Nm with the provided 4 mm Ball End Allen Key or a suitable Torque Wrench.

NOTE - The Pivot Mount assembly will still have movement after securing which is intended.

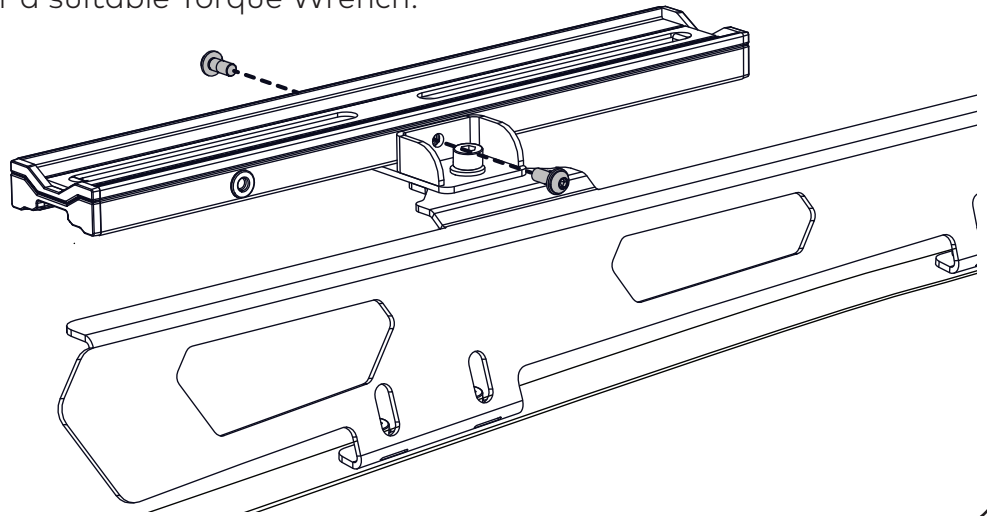

NOW SWITCH TO YOUR LOCKNLOAD PLATFORM INSTRUCTIONS AND CONTINUE FROM THE 'VEHICLE MOUNTING INSTRUCTIONS' PAGE.

This page intentionally left blank



www.yakima.com.au
www.yakima.co.nz
www.yakima.com
www.yakima.eu

YAKIMA AUSTRALIA PTY LTD

17 Hinkler Court
Brendale, QLD 4500
Australia
1800 143 548
yakimaglobal.com

YAKIMA PRODUCTS, INC.

4101 Kruse Way
Lake Oswego, OR
97035-2541
USA
888 925 4621
yakima.com/support