



# LockNLoad™ Flush Rail Mounting Kit

ISUZU D-MAX 2021+  
FLUSH RAIL HEAVY DUTY PLATFORM SYSTEM

**MAXIMUM PRODUCT LOAD RATING: 100 kg**



**IMPORTANT:**

- **LOAD = WEIGHT OF PLATFORM or BARS + MOUNTING SYSTEM + ACCESSORIES + CARGO**
- **PLEASE REFER TO VEHICLE MANUFACTURER SPECIFICATIONS FOR MAX ROOF LOAD CAPACITY OF VEHICLE. THE LOWEST LOAD RATING APPLIES.**
- **OFFROAD RATING: SCAN QR CODE FOR LOCKNLOAD LOAD RATING GUIDE. REDUCTIONS MAY APPLY.**



## FIRST TIME INSTALLATION

- Please read instructions carefully before installation.
- Check the contents of kit. Contact your YAKIMA dealer if any parts appear missing or damaged.
- Clean your roof thoroughly prior to fitting the LockNLoad Flush Rail Heavy Duty Roof Rack System.
- Place these instructions in the vehicle's glove box after installation is complete.



**TOOLS REQUIRED:**

- 4 mm Ball End Allen Key
- 5 mm Allen Key
- 13 mm Ring Spanner
- Tape Measure
- Torque Wrench (Optional)

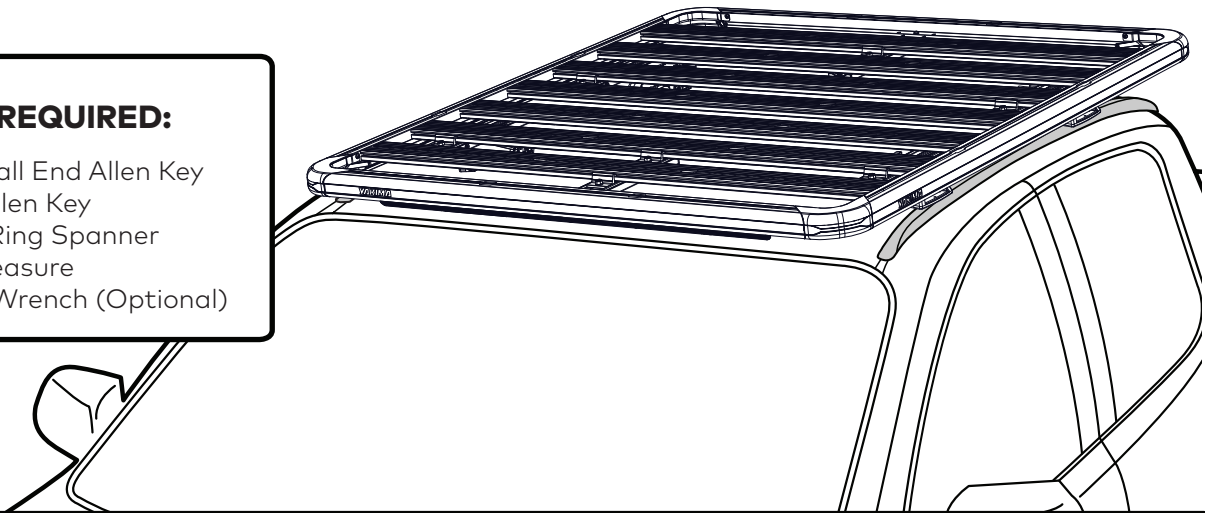

## KIT CONTENTS

ITEM	COMPONENT	QTY	ITEM	COMPONENT	QTY
1.	Flush Rail Leg Assembly	x4	2.	Key Set	x1

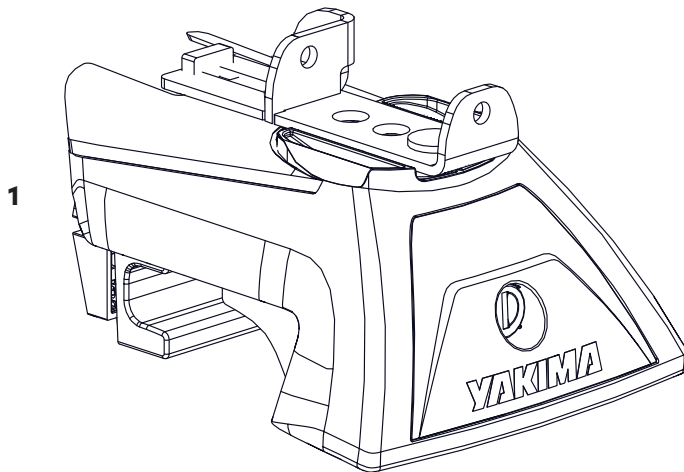

**PLATFORM SOLD SEPARATELY**

**9831005**

# INSTALLATION OF LOCKLOAD PLATFORM TO FLUSH RAIL LEGS

## 1 REMOVE LEG COVERS

Using the keys supplied, remove all Leg Covers.

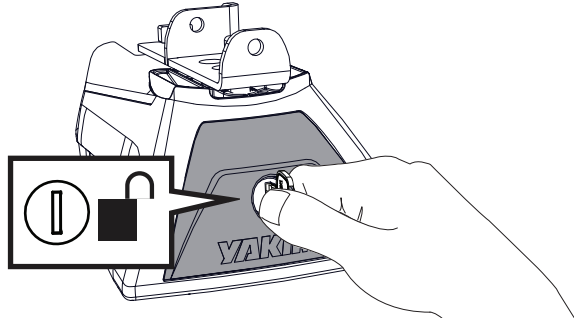

## 2 INSTALL MOUNTING BLOCKS

Place Mounting Block from Platform kit (sold separately) on top of each Leg assembly, lining up the rivnut holes on Mounting Block with holes on tabs of Leg Mounting Bracket.

Secure with M6 Capscrews with Washers from Platform kit, as shown. Tighten all screws to 4 Nm with a 4 mm Ball End Allen Key or suitable Torque Wrench.

**NOTE** - The Mounting Block assembly will still have movement after securing which is intended.

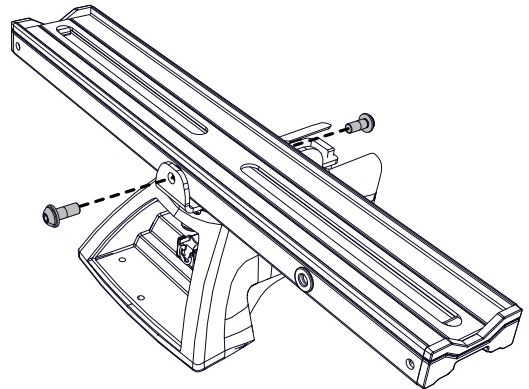
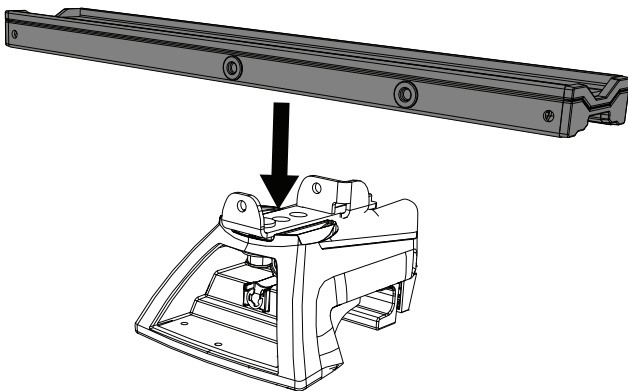

## 3 LEG LOCATION

**Legs should only be placed on aluminum rail. Do not place Legs on plastic rail covers.**

Position front Legs onto the vehicle rail so that they are centred 164 mm forward from rear of front door.

Position rear Legs onto the vehicle rail so that they are centred 466 mm behind the rear of front door.

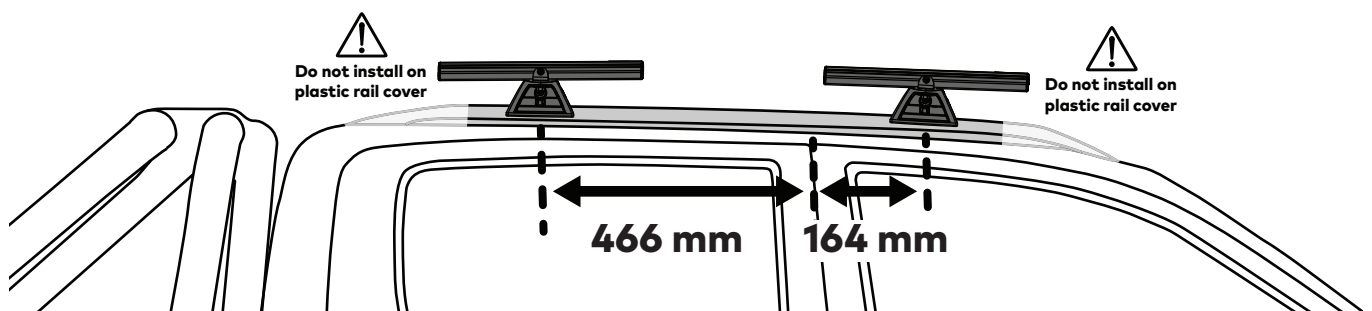

**4****SECURE LEGS**

Secure Leg assemblies to the vehicle rail using a 5 mm Allen Key or Torque Wrench. Torque until there is no gap visible between rail and Leg assembly.

**Do NOT tighten firmly, final torque to be done in Step 9.**

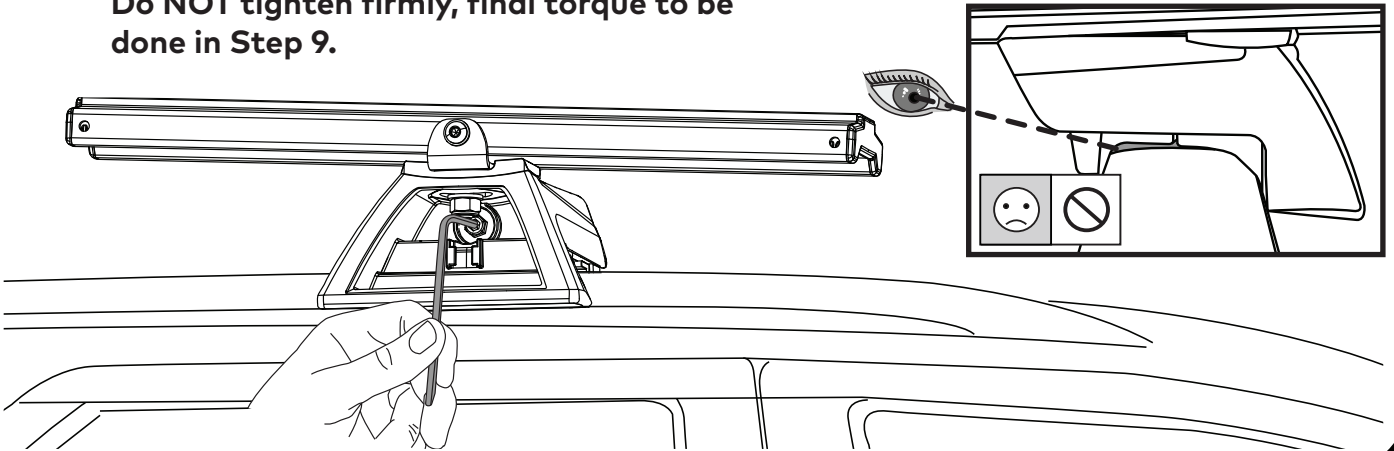
**5****ASSEMBLE LOCKNLOAD PLATFORM**

If Platform was purchased unassembled, follow Steps 1 - 9 on Pages 4 - 7 of the Platform Assembly instructions (footer number 28-13-337) to piece Platform together.

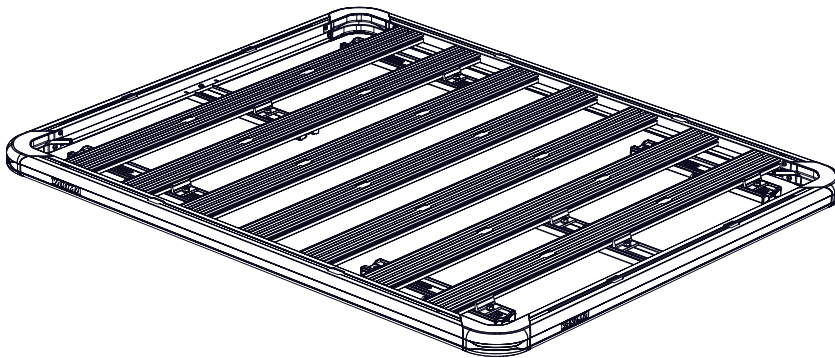
**6****LIFT PLATFORM ONTO VEHICLE**

With the help of an assistant, carefully lift assembled Platform up and onto Mounting Blocks on vehicle roof. Centre Platform evenly on Legs so there is equal overhang on both sides and ideally at front and rear.

**Follow LockNLoad Platform Vehicle Mounting instructions from Step 3 to complete install.**

**NOTE - Wind Deflector, if used, is to be installed at the front of the vehicle (sold separately).**

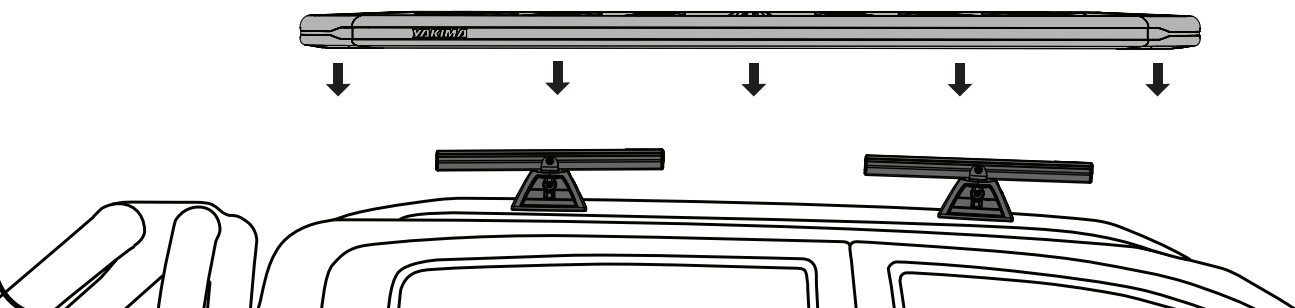

**7****CHECK LEG FITMENT**

Recheck Leg assemblies to the vehicle rail using a 5 mm Allen Key or Torque Wrench. Re-torque until there is no gap visible between rail and Leg assembly. **Do NOT tighten firmly, final torque to be done in Step 9.**

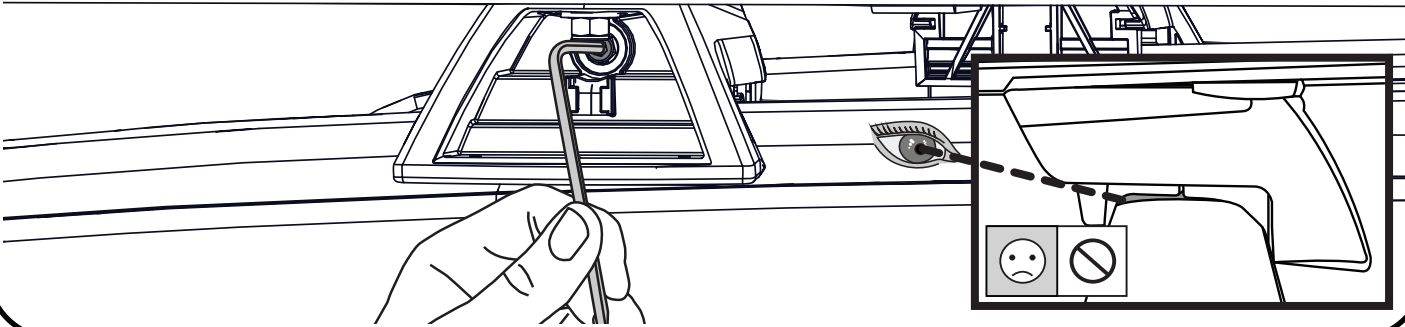
**YAKIMA****8****TIGHTEN PIVOT ASSEMBLY**

Use a Spanner or Torque Wrench to tighten M8 Nuts on each Leg to 7 Nm.

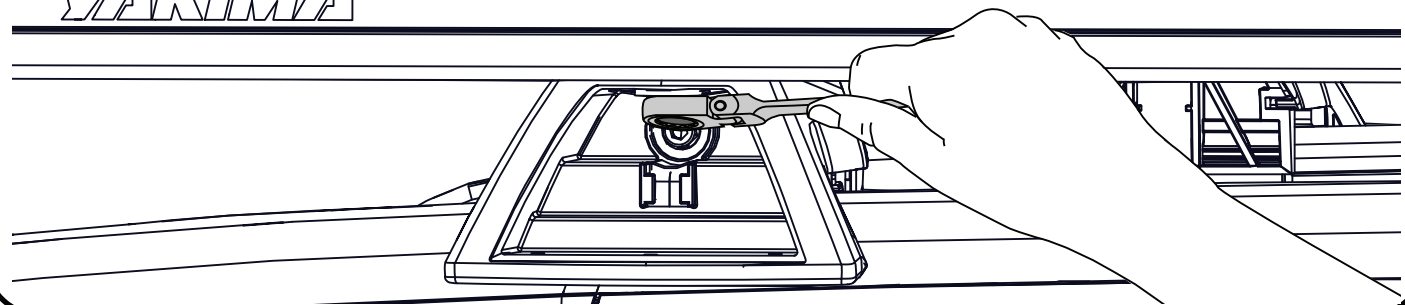
**YAKIMA****9****TORQUE LEG BOLTS**

Torque Leg assemblies to the vehicle rail using a 5 mm Allen Key or Torque Wrench to 4 Nm.

**A small gap on the inside clamp is OK at this step, however if there is a large gap or weak clamp force, repeat steps 7 & 8.**

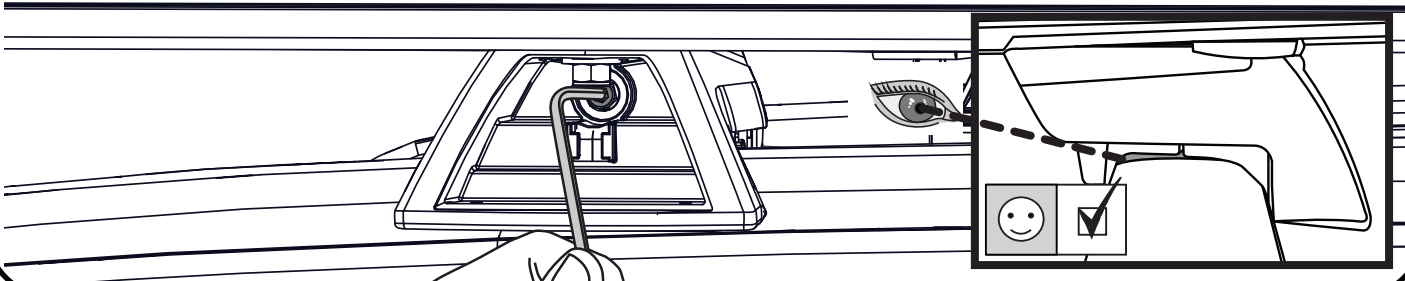
**YAKIMA**

**10****FIT LEG COVERS**

Fit Covers onto Legs and lock using the keys supplied in the LockNLoad Leg Kit.

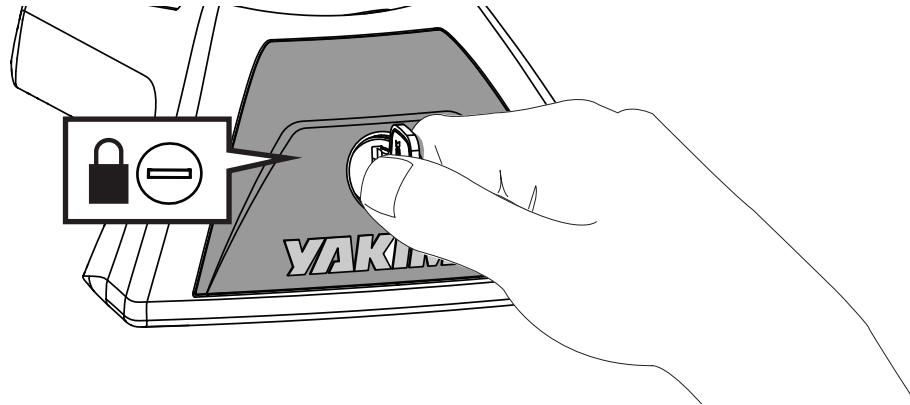
**11****LEG KEYS**

Place one key on the vehicle key ring and put the other away safely, or store with the spare vehicle key.

Write the key number (which is stamped on the key) in the box provided.  
Replacement keys are available from Yakima stockists, visit [www.yakima.com.au](http://www.yakima.com.au)  
or [www.yakima.co.nz](http://www.yakima.co.nz) to find your nearest store or contact us directly on 1800 143  
548 (AU) or 0800 4776 722 (NZ).

**Key Number:**

A dashed rectangular box for writing the key number.

**YAKIMA**

[www.yakima.com.au](http://www.yakima.com.au)

[www.yakima.co.nz](http://www.yakima.co.nz)

[www.yakima.com](http://www.yakima.com)

[www.yakima.eu](http://www.yakima.eu)

**YAKIMA AUSTRALIA PTY LTD**

17 Hinkler Court  
Brendale, QLD 4500  
Australia  
1800 143 548

**YAKIMA PRODUCTS, INC.**

4101 Kruse Way  
Lake Oswego, OR  
97035-2541  
USA  
888 925 4621

**ALL CONTENT SUBJECT TO YAKIMA AUSTRALIA PTY LTD COPYRIGHT © 2020**